



# Cisco UCS 5108 Blade Server Chassis

CISCO SYSTEMS  
170 WEST TASMAN DR.  
SAN JOSE, CA, 95134  
[WWW.CISCO.COM](http://WWW.CISCO.COM)

#### PUBLICATION HISTORY

REV A.5    MARCH 18, 2013

---

# CONTENTS

<b>OVERVIEW</b>	<b>3</b>
<b>DETAILED VIEWS</b>	<b>4</b>
Chassis Front Views	4
Chassis Rear View	6
Fabric Extender Modules	7
<b>BASE CHASSIS STANDARD CAPABILITIES and FEATURES</b>	<b>8</b>
<b>CONFIGURING the CHASSIS</b>	<b>10</b>
STEP 1 VERIFY BASE CHASSIS SKU	11
STEP 2 SELECT FABRIC I/O EXTENDERS	12
STEP 3 CHOOSE ADDITIONAL COMPONENTS (OPTIONAL)	13
STEP 4 CHOOSE POWER SUPPLIES	15
STEP 5 SELECT AC POWER CORD(s)	16
STEP 6 CHOOSE OPERATING SYSTEM (OPTIONAL)	17
STEP 7 CHOOSE SERVICE and SUPPORT LEVEL	18
<b>SUPPLEMENTAL MATERIAL</b>	<b>20</b>
System Overview	20
Connectivity Between Blades and Fabric Extenders	21
B200/B230 M1/M2Connectivity (Half-Width Blades with One Mezzanine Slot)	22
B250/B440 M1/M2 Connectivity (Full-Width Blades with Two Mezzanine Slots)	26
B22/B00 M3 Connectivity (Half-Width Blades with Two Mezzanine Slots)	30
B420 M3 Connectivity (Full-Width Blade with Three Mezzanine Slots)	35
Connectivity Between Fabric Extender and Fabric Interconnect	40
SFP+ Transceivers	41
Copper SFP+ Twinax Transceivers	41
Optical SFP+ Transceivers	42
Fabric Extender Bundles	42
<b>TECHNICAL SPECIFICATIONS</b>	<b>43</b>
Physical Dimensions and Specifications	43
Power Specifications	44
Environmental Specifications	47

## OVERVIEW

The UCS 5108 chassis is a 6RU chassis that can accommodate up to 8 half-width blades or 4 full-width blades, or any combination that will fit in the chassis. The chassis has two I/O bays for Fabric Extenders such as the UCS 2208XP.

*Figure 1* shows the front and rear views of a 5108 chassis filled with the following blade servers (starting from top):

- Two Cisco UCS B200 M3 half-width blade servers
- One Cisco UCS B250 M2 full-width blade server
- One Cisco UCS B420 M3 full-width blade server
- One Cisco UCS B440 M2 full-width blade server

Figure 1 Cisco UCS 5108 Blade Server Chassis (front view)



Figure 2 Cisco UCS 5108 Blade Server Chassis (rear view)



# DETAILED VIEWS

## Chassis Front Views

Figure 3 is a detailed front view of the Cisco UCS 5108 Blade Server Chassis with eight half-width blade servers installed.

Figure 3 5108 Chassis Front View With Eight Half-Width Blade Servers Installed

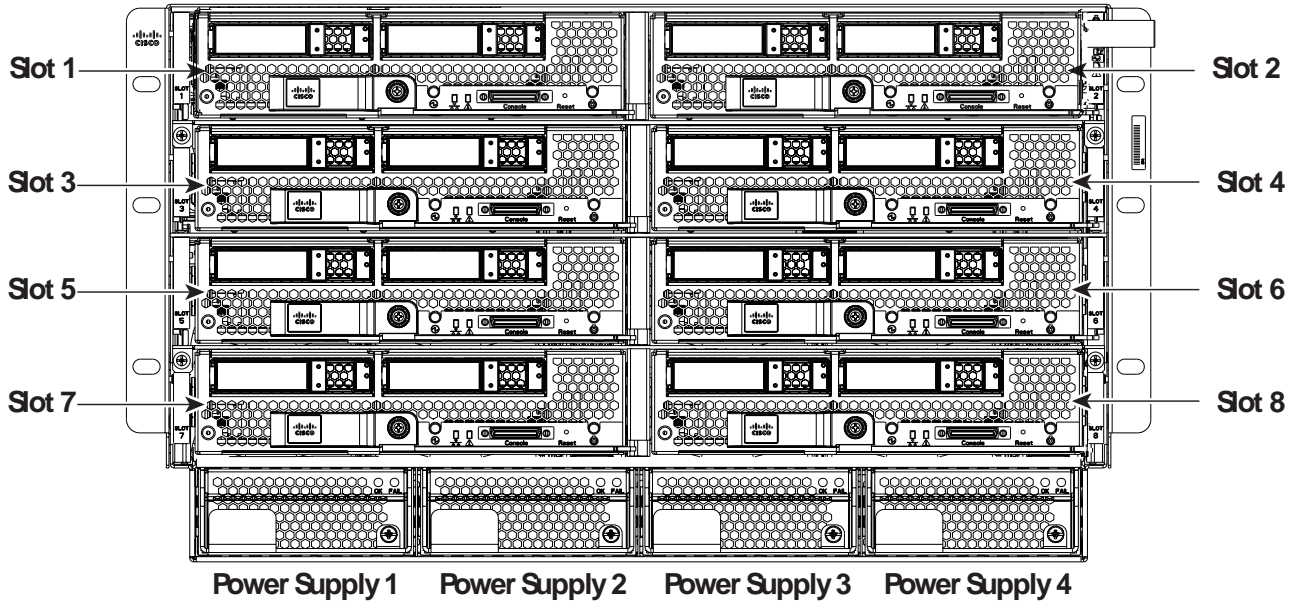

Table 1 Front View Callouts

Callout	Description
Slot 1 - 8	Slot numbering for half-width blade servers
Power Supply 1 - 4	4 x 2500 W power supplies

Figure 4 is a detailed front view of the Cisco UCS 5108 Blade Server Chassis with four full-width blade servers installed.

Figure 4 5108 Chassis Front View With Four Full-Width Blade Servers Installed

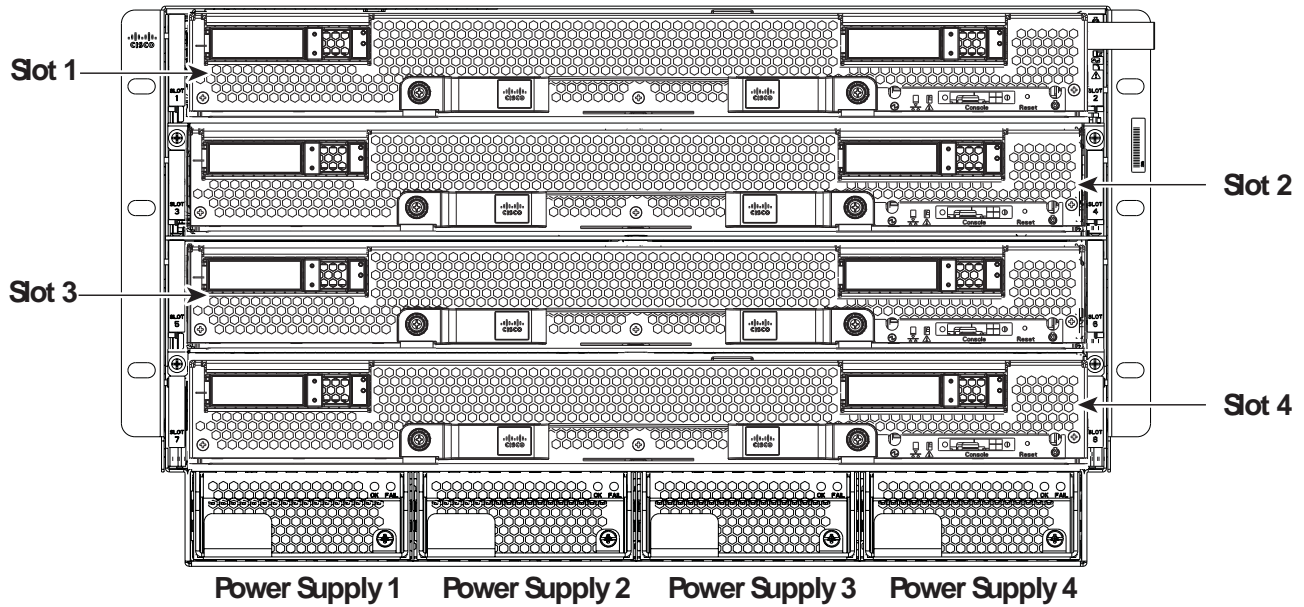

Table 2 Front View Callouts

Callout	Description
Slot 1 - 4	Slot numbering for full-width blade servers
Power Supply 1 - 4	4 x 2500 W power supplies

## Chassis Rear View

Figure 5 shows the rear view of the 5108 chassis (AC power version).

Figure 5 Chassis Rear View (AC power supplies)

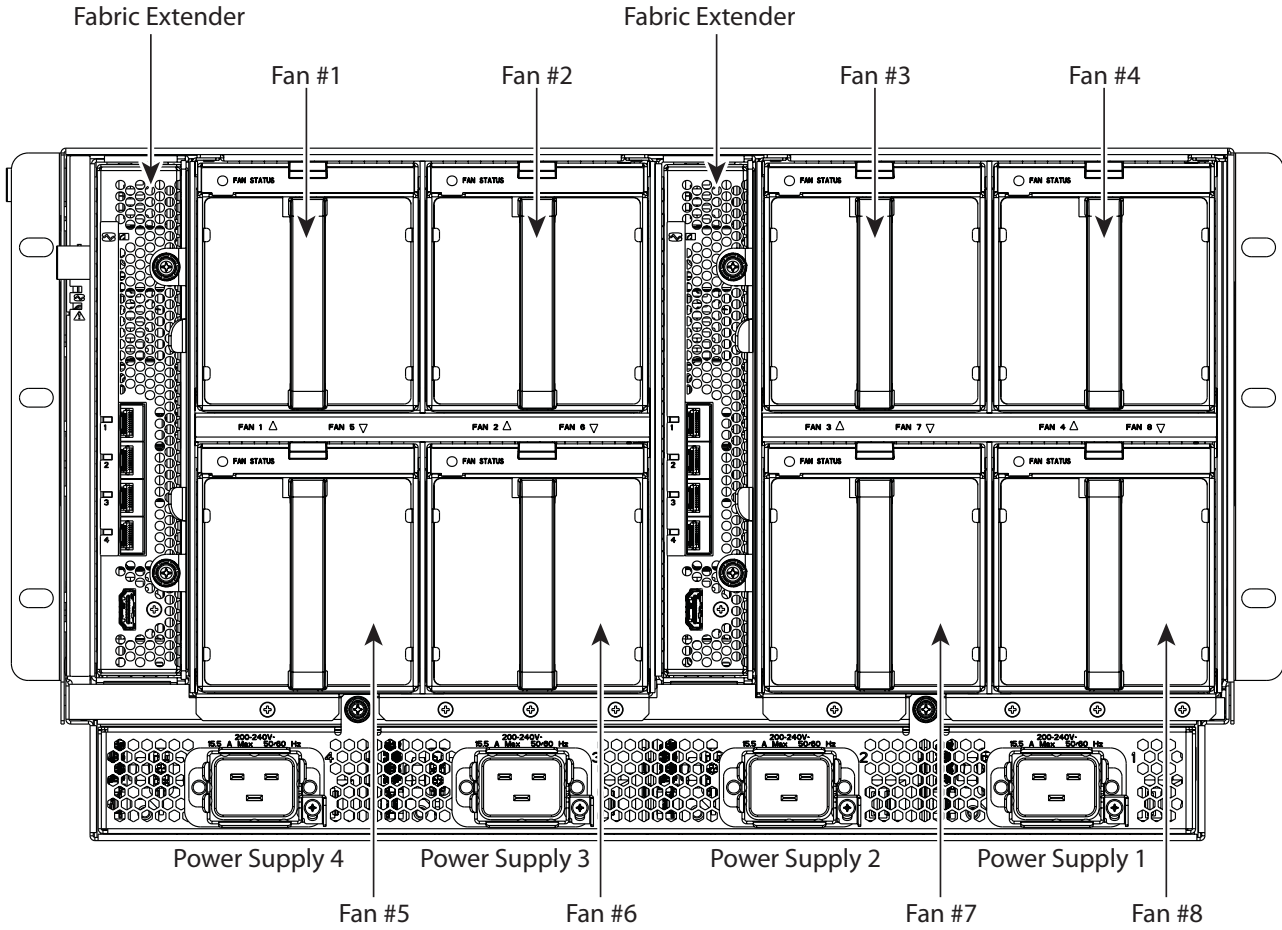

## Fabric Extender Modules

The Fabric Extender modules (up to two) plug into the back of the UCS 5108 series blade server chassis. A midplane connects the blade servers to the Fabric Extenders. The 5108 chassis accommodates the following Fabric Extender modules:

- Cisco UCS 2208XP
- Cisco UCS 2204XP
- Cisco UCS 2104XP

Figure 5 shows the Fabric Extenders.

Figure 6 2208XP, 2204XP, and 2104XP Fabric Extenders

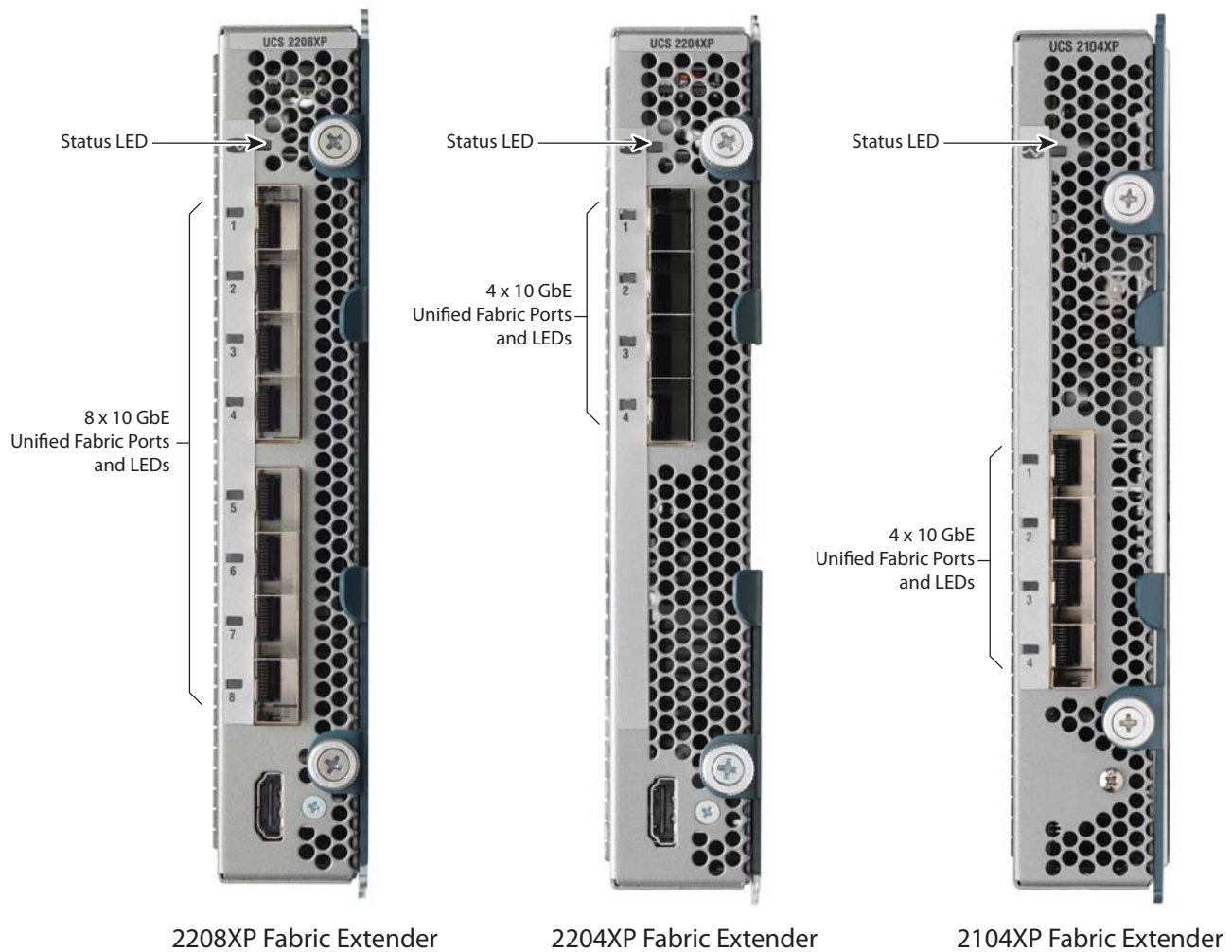

## BASE CHASSIS STANDARD CAPABILITIES and FEATURES

*Table 3* lists the capabilities and features of the base 5108 chassis. Details about how to configure the chassis for a particular feature or capability are provided in *CONFIGURING the CHASSIS on page 10*.

Table 3 Capabilities and Features

Capability/Feature	Description
Management by Cisco UCS Manager	<ul style="list-style-type: none"> <li>■ Reduces TCO by removing management modules from the chassis, making the chassis stateless, and UCS systems management inherently scalable</li> <li>■ Provides a single, highly available management domain for all system chassis, reducing administrative tasks through automated service profile configuration</li> </ul>
 <b>NOTE:</b> The 5108 blade chassis requires UCS Manager version 2.1 or later	
Unified fabric	Decreases TCO by reducing the number of network interface cards (NICs), host bus adapters (HBAs), switches, and cables needed
Support for one or two Cisco UCS 2100 or 2200 Series Fabric Extenders	<ul style="list-style-type: none"> <li>■ Eliminates switches from the chassis along with complex configuration and management of those switches, allowing a system to scale without adding complexity and cost</li> <li>■ Allows use of two fabric extenders for redundancy or aggregation of bandwidth</li> <li>■ Enables bandwidth scaling based on application needs; blades can be configured for 1.25 Gbps to 10 Gbps or more</li> </ul>
Auto-discovery	Requires no configuration; like all components in the Cisco Unified Computing System, chassis are automatically recognized and configured by Cisco UCS Manager and its service profiles and service profile groups
High-performance mid-plane	<ul style="list-style-type: none"> <li>■ Provides investment protection</li> <li>■ Supports up to 2x 40 Gbit Ethernet links to each half-width blade slot or up to 4x 40 Gbit links to each full-width slot</li> <li>■ Provides 8 blades with 1.2 terabits (Tb) of available Ethernet throughput for future I/O requirements</li> <li>■ Provides reconfigurable chassis to accommodate a variety of form factors and functions</li> </ul>
Redundant hot-swappable power supplies and fans	<ul style="list-style-type: none"> <li>■ Provides high availability in multiple configurations</li> <li>■ Provides uninterrupted service during maintenance</li> </ul>
Hot-swappable blade servers and fabric extenders	Provides uninterrupted service during maintenance and server deployment



Table 3 Capabilities and Features *(continued)*

Capability/Feature	Description
Comprehensive monitoring	<ul style="list-style-type: none"><li>■ Provides extensive environmental monitoring on each chassis</li><li>■ Allows use of user thresholds to optimize environmental management of the chassis</li></ul>
Thermal efficiencies	The Chassis Management Controller (CMC) monitors all the temperature sensors and regulates fan speeds to maintain the airflow at the minimum needed to cool the system. The open backplane and deep plenum allow air to be directed across the blades to ensure cooling is directed where it is needed most.
Tool-free installation	<ul style="list-style-type: none"><li>■ Requires no specialized tools for chassis installation</li><li>■ Provides mounting rails for easy installation and servicing</li></ul>
Mixed blade configurations	The UCS 5108 Server Chassis can accommodate a maximum of 8 half-width server blades or 4 full-width server blades or any combinations of the two sizes that will fit in the chassis.

## CONFIGURING the CHASSIS

Follow these steps to configure the Cisco UCS 5108 chassis:

- *STEP 1 VERIFY BASE CHASSIS SKU, page 11*
- *STEP 2 SELECT FABRIC I/O EXTENDERS, page 12*
- *STEP 3 CHOOSE ADDITIONAL COMPONENTS (OPTIONAL), page 13*
- *STEP 4 CHOOSE POWER SUPPLIES, page 15*
- *STEP 5 SELECT AC POWER CORD(s), page 16*
- *STEP 6 CHOOSE OPERATING SYSTEM (OPTIONAL), page 17*
- *STEP 7 CHOOSE SERVICE and SUPPORT LEVEL, page 18*
- *SUPPLEMENTAL MATERIAL on page 20*

## STEP 1 VERIFY BASE CHASSIS SKU

Verify the product ID (PID) of the base 5108 chassis as shown in [Table 4](#). Note that you can order either an AC-powered or DC-powered version of the chassis.

Table 4 PID of the Base 5108 Chassis

Product ID (PID)	Description
N20-C6508	AC-powered version of the Cisco UCS 5108 Blade Server Chassis
UCSB-5108-DC	DC-powered version of the Cisco UCS 5108 Blade Server Chassis

Included with AC and DC versions:

- N20-CAK: Chassis Accessory Kit, consisting of:
  - N20-CRMK2: One Rail kit that supports square-holed racks (or round hole racks with an optional adapter - see below)
  - N20-BKVM=: KVM local console connector dongle cable that connects to the front of any UCS blade server, and documentation
  - N20-FAN5: Eight redundant and hot-swappable fan modules

Not included with AC or DC versions (but may be ordered separately):

- N20-CRMK2=: Additional or spare rail kit for the Cisco UCS 5108 chassis
- N20-CRMK2-RHA=: Round hole adapter kit (for threaded and non-threaded holes) for the rail kit (N20-CRMK2) included with the chassis.



NOTE: The adapter kit only works with the N20-CRMK2 rail kit

### Caveats

- You must select either an AC or DC version of the 5108 chassis.
- There is no mixing allowed of AC and DC power supplies within the same 5108 chassis.

## STEP 2 SELECT FABRIC I/O EXTENDERS

The Fabric I/O Extender options are:

- Cisco UCS 2208XP
- Cisco UCS 2204XP
- Cisco UCS 2104XP

### Choose Fabric I/O Extenders

The available Fabric I/O Extenders are listed in [Table 5](#). Each Fabric I/O Extender connects to the Fabric Interconnect 6100 series modules by means of several ports of 10GbE and Fibre Channel over Ethernet (FCoE).

Table 5 Available Fabric I/O Extenders

Product ID (PID)	Fabric I/O Extender	Number of 10GbE/FCoE Ports to Fabric Interconnect	Number of Internal 10GbE/FCoE Ports	Total Chassis I/O per Fabric Extender
UCS-IOM-2208XP	2208XP	8	32	80 Gbs
UCS-IOM2208-16FET	Bundle that includes one 2208XP plus 16 Fabric Extender Transceivers (FETs) <sup>1</sup>	8	32	80 Gbs
UCS-IOM-2204XP	2204XP	4	16	40 Gbs
UCS-IOM2204-8FET	Bundle that includes one 2204XP plus 8 Fabric Extender Transceivers (FETs) <sup>1</sup>	4	16	40 Gbs
N20-I6584	2104XP	4	8	40 Gbs

Notes . . .

1. For more information on Fabric Extender bundles, see [Fabric Extender Bundles on page 42](#).

### Approved Configurations

- (1) Choose one or two identical Fabric I/O Extenders, or
- (2) Choose one or two identical Fabric Extender bundles (includes one Fabric Extender plus transceivers)

### Caveats

- You must select either one or two identical Fabric I/O Extenders or bundles.
- Do not use any Fabric Extender transceivers other than those that come in the bundles.

### STEP 3 CHOOSE ADDITIONAL COMPONENTS (OPTIONAL)

A variety of optical and copper Small Form-Factor Pluggable (SFP) transceivers and copper twinax cables are available for use with the Fabric Extenders.

#### Choose SFP+ Optical Transceivers

---

You can choose up to eight SFP+ optical transceivers for each 2208XP, or up to four for each 2204XP or 2104XP, as shown in [Table 6](#).

Table 6 SFP+ Transceivers

Product ID (PID)	PID Description
SFP-10G-SR	10 Gigabit Ethernet - short range SFP+ module (MMF)
SFP-10G-LR	10 Gigabit Ethernet - long range SFP+ module (SMF)

#### Choose SFP Optical or Copper Transceivers

---

You may choose up to eight SFP optical or copper transceivers for each 2208XP, or up to four for each 2204XP or 2104XP, as shown in [Table 7](#).

Table 7 SFP Optical Transceivers

Product ID (PID)	PID Description
GLC-T	1 GbE copper SFP Module
GLC-SX-MM	1 GbE short range (550 m max) SFP Module
GLC-LH-SM	1 GbE long range (10 km max) SFP Module
SFP-GE-T	1 GbE SFP, extended temperature range Module
SFP-GE-S	1 GbE SFP, LC connector SX transceiver (MMF), ext. temp. range and DOM
SFP-GE-L	1 GbE SFP, LC connector LX/LH transceiver (SMF), ext. temp. range and DOM

### Choose Twinax Copper Cables

---

You can choose twinax copper cables of various lengths (from 1 to 10 meters) as shown in [Table 8](#). The two longer cables (7 and 10 meters) are active, which means that they contain active components within the SFP+ connector housing to improve signal quality. The ends of these cables are connectorized and plug directly into the Fabric Extender SFP receptacles on one end and into the Fabric Interconnect SFP receptacles on the other end.

Table 8 Twinax Copper Cables

Product ID (PID)	PID Description
SFP-H10GB-CU1M	10 G Base-CU SFP+, 1 meter (twinax cable)
SFP-H10GB-CU3M	10 G Base-CU SFP+, 3 meter (twinax cable)
SFP-H10GB-CU5M	10 G Base-CU SFP+, 5 meter (twinax cable)
SFP-H10GB-ACU7M	10 G Base-CU SFP+, 7 meter (twinax cable)
SFP-H10GB-ACU10M	10 G Base-CU SFP+, 10 meter (twinax cable)

### Approved Configurations

---

(1) Choose the number of transceivers or copper twinax cables according to the number of Fabric Extender ports that are active that or will be become active in the future.

### Caveats

---

- You should order enough SFPs and cables to accommodate your maximum foreseeable needs.

## STEP 4 CHOOSE POWER SUPPLIES

The 5108 chassis accommodates up to four power supplies.

### Choose Power Supplies

---

The available power supplies are listed in [Table 9](#).

Table 9 Available Power Supplies

Product ID (PID)	PID Description
N20-PAC5-2500W	2500 W AC power supply, redundant and hot-swappable (80Plus Gold Certified)
UCSB-PSU-2500ACPL	2500 W AC hot-pluggable power supply (80Plus Platinum Certified)
UCSB-PSU-2500DC48	2500 W DC -48 V power supply

### Approved Configurations

---

(1) Choose from 2 to 4 power supplies

### Caveats

---

- Do not mix AC and DC power supplies
- Use the 2500 W DC power supply (UCSB-PSU-2500DC48) only with the DC-powered version of the 5108 chassis (UCSB-5108-DC).
- Use the 2500 W AC power supplies (N20-PAC5-2500W or UCSB-PSU-2500ACPL) only with the AC-powered version of the 5108 chassis (N20-C6508).

## STEP 5 SELECT AC POWER CORD(S)

Select the appropriate AC power cords listed in [Table 10](#). You may select up to 4 power cords.

Table 10 Available Power Cords

Product ID (PID)	PID Description	Comment
CAB-AC-16A-AUS	16A, 250 VAC	Australia
UCSB-CABL-C19-BRZ	16A, 250 VAC	Brazil
CAB-AC16A-CH	16A, 250 VAC	China
CAB-AC-2500W-EU	16A, 250 VAC	Europe
CAB-AC-2500W-INT	16A, 250 VAC	International
CAB-AC-2500W-ISRL	16A, 250 VAC	Israel
CAB-AC-2500W-US1	16A, 250 VAC	NEMA 6-20P
CAB-AC-C6K-TWLK	20A, 250 VAC (twist-lock)	NEMA L6-20
CAB-ACS-16	16A, 250 VAC	Switzerland
CAB-C19-CBN	16A, 250 VAC	Jumper cord C19/C20



## STEP 6 CHOOSE OPERATING SYSTEM (OPTIONAL)

Several operating systems are available from which to choose. Choose one of the operating systems listed in [Table 11](#).

Table 11 Operating Systems

Product ID (PID)	PID Description
SUSE Linux Enterprise Server	
SLES-11	SLES 11 media only (multilingual)
SLES-CA-1A	SLES, 1-year subscription, services required, no media
SLES-CA-3A	SLES, 3-year subscription, services required, no media

## STEP 7 CHOOSE SERVICE and SUPPORT LEVEL

A variety of service options are available, as described in this section.

### Unified Computing Warranty, No Contract

If you have noncritical implementations and choose to have no service contract, the following coverage is supplied:

- Three-year parts coverage.
- Next business day (NBD) parts replacement eight hours a day, five days a week.
- 90-day software warranty on media.
- Downloads of BIOS, drivers, and firmware updates.
- UCSM updates for systems with Unified Computing System Manager. These updates include minor enhancements and bug fixes that are designed to maintain the compliance of UCSM with published specifications, release notes, and industry standards.

### Unified Computing Mission Critical Service

This service delivers personalized technical account management, expedited technical support, and expert field support engineering for the Cisco Unified Computing System (UCS).

The Mission Critical Support Service provides a designated technical account manager (TAM) who acts as a strategic resource to help ensure that the unified computing environment runs at peak efficiency. If a problem arises that threatens business continuity, the TAM provides crisis management leadership, and your IT staff receives expedited access to Cisco's Technical Assistance Center (TAC).

Please note: This service has qualification criteria. Your company must have \$1.2M of UCS equipment, 200 blades and a single location to qualify for this service level. Choose the desired service listed in [Table 12](#).

Table 12 Unified Computing Mission Critical Service

Product ID (PID)	On Site?	Description
CON-UCM7-2C6508	Yes	UC Mission Critical 24x7x4 On-site
CON-UCM8-2C6508	Yes	UC Mission Critical 24x7x2 On-site

### Unified Computing Support Service

For support of the entire Unified Computing System, Cisco offers the Cisco Unified Computing Support Service. This service provides expert software and hardware support to help sustain performance and high availability of the unified computing environment. Access to Cisco Technical Assistance Center (TAC) is provided around the clock, from anywhere in the world.

For UCS blade servers, there is Smart Call Home, which provides proactive, embedded diagnostics and real-time alerts. For systems that include Unified Computing System Manager, the support service includes downloads of UCSM upgrades. The Unified Computing Support Service includes flexible hardware replacement options, including replacement in as little as two hours. There is also access to Cisco's extensive online technical resources to help maintain

optimal efficiency and uptime of the unified computing environment. You can choose a desired service listed in [Table 13](#).

Table 13 UCS Computing Support Service

Product ID (PID)	On Site?	Description
CON-UCS1-2C6508	No	UC Support 8X5XNBD
CON-UCS2-2C6508	No	UC Support 8X5X4
CON-UCS3-2C6508	No	UC Support 24x7x4
CON-UCS4-2C6508	No	UC Support 24x7x2
CON-UCS5-2C6508	Yes	UC Support 8X5XNBD
CON-UCS6-2C6508	Yes	UC Support 8X5X4
CON-UCS7-2C6508	Yes	UC Support 24x7x4
CON-UCS8-2C6508	Yes	UC Support 24x7x2

#### Unified Computing Warranty Plus Service

For faster parts replacement than is provided with the standard Cisco Unified Computing System warranty, Cisco offers the Cisco Unified Computing Warranty Plus Service. You can choose from several levels of advanced parts replacement coverage, including onsite parts replacement in as little as two hours. Warranty Plus provides remote access any time to Cisco support professionals who can determine if a return materials authorization (RMA) is required. You can choose a service listed in [Table 14](#).

Table 14 UCS Computing Warranty Plus Service

Product ID (PID)	On Site?	Description
CON-UCW3-2C6508	No	UC Warranty Plus 24x7x4
CON-UCW5-2C6508	Yes	UC Warranty Plus 8X5XNBD

For more service and support information, see the following URL:

[http://www.cisco.com/en/US/services/ps2961/ps10312/ps10321/Cisco\\_UC\\_Warranty\\_Support\\_DS.pdf](http://www.cisco.com/en/US/services/ps2961/ps10312/ps10321/Cisco_UC_Warranty_Support_DS.pdf)

For a complete listing of available services for Cisco Unified Computing System, see this URL:

[http://www.cisco.com/en/US/products/ps10312/serv\\_group\\_home.html](http://www.cisco.com/en/US/products/ps10312/serv_group_home.html)

# SUPPLEMENTAL MATERIAL

## System Overview

The Cisco Unified Computing System™ (Cisco UCS™) is a next-generation data center platform that unites compute, network, storage access, and virtualization resources into a cohesive system designed to reduce total cost of ownership (TCO) and increase business agility. The system integrates a low-latency, lossless 10 Gigabit Ethernet unified network fabric with enterprise-class, x86-architecture servers. The system is an integrated, scalable, multichassis platform in which all resources participate in a unified management domain (see *Figure 7*).

Figure 7 System Diagram

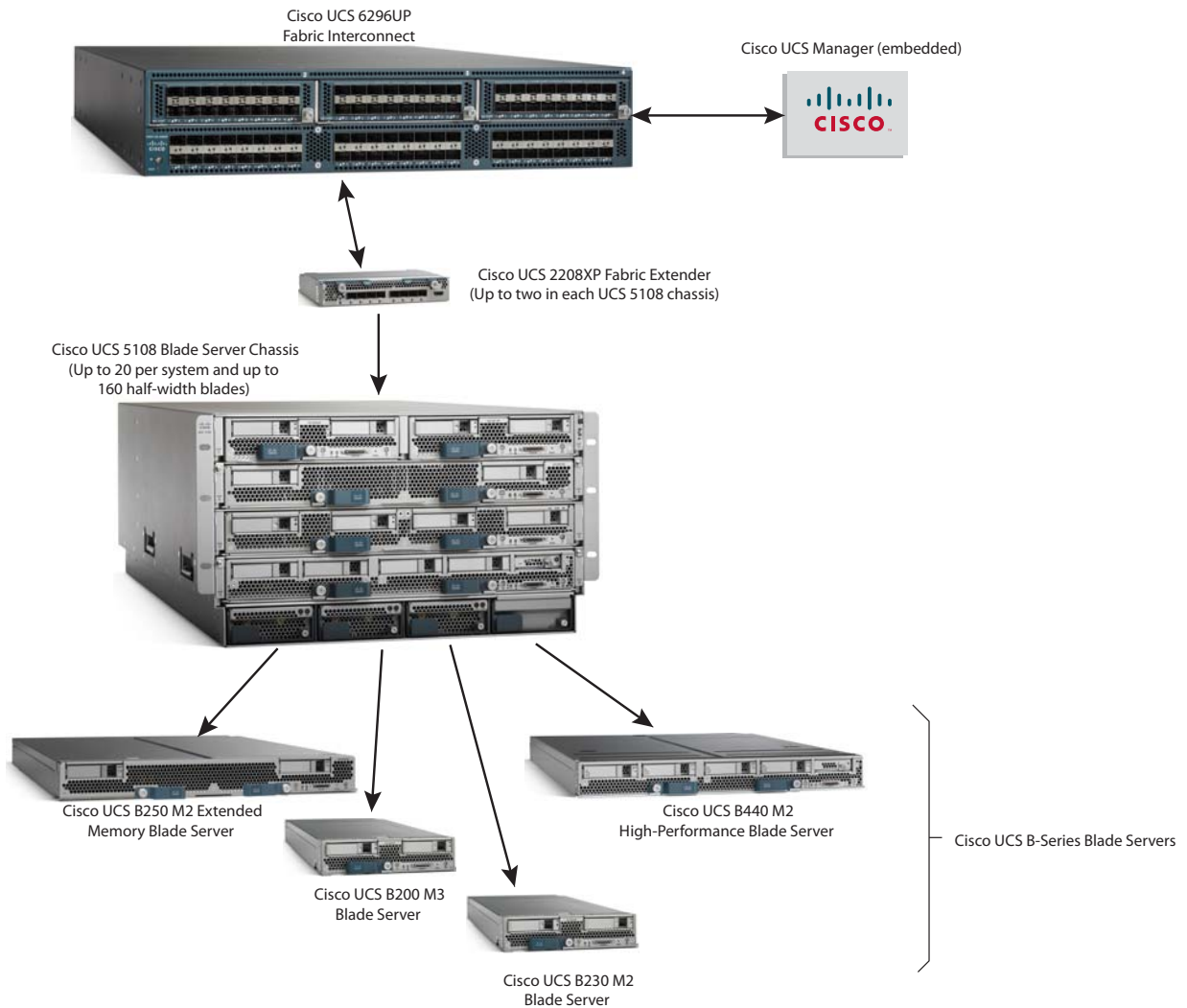

## Connectivity Between Blades and Fabric Extenders

Cisco UCS Fabric Extenders bring the unified fabric into the blade server enclosure, providing multiple 10 Gigabit Ethernet connections between blade servers and the fabric interconnect, simplifying diagnostics, cabling, and management.

The Fabric Extenders extend the I/O fabric between the Cisco UCS 6100 and 6200 Series Fabric Interconnects and the Cisco UCS 5108 Blade Server Chassis, enabling a lossless and deterministic Fibre Channel over Ethernet (FCoE) fabric to connect all blades and chassis together. Since the fabric extender is similar to a distributed line card, it does not perform any switching and is managed as an extension of the fabric interconnects. This approach removes switching from the chassis, reducing overall infrastructure complexity and enabling Cisco UCS to scale to many chassis without multiplying the number of switches needed, reducing TCO and allowing all chassis to be managed as a single, highly available management domain.

The Fabric Extenders also manage the chassis environment (the power supply and fans as well as the blades) in conjunction with the fabric interconnect. Therefore, separate chassis management modules are not required.

The Fabric Extenders fit into the back of the Cisco UCS 5108 chassis. Each Cisco UCS 5108 chassis can support up to two fabric extenders, allowing increased capacity and redundancy.

Connectivity between each unique blade and the Fabric Extenders varies according to the type of blade, its available adapter card slots, and the type of card plugged into each slot. See the individual blade server spec sheets for detailed connectivity information and connectivity diagrams at this link:

[http://www.cisco.com/en/US/products/ps10280/products\\_data\\_sheets\\_list.html](http://www.cisco.com/en/US/products/ps10280/products_data_sheets_list.html)

The following sections show generally how the various blade connect to the Fabric Extenders.

### B200/B230 M1/M2 Connectivity (Half-Width Blades with One Mezzanine Slot)

Figure 8 shows in general how the B200/B230 M1/M2 blade servers connect to the fabric extenders in the UCS 5108 chassis. Several cards are available for use in the card adapter slot (see Table 15 on page 23).

Figure 8 B200/B230 M1/M2 to Fabric Extenders

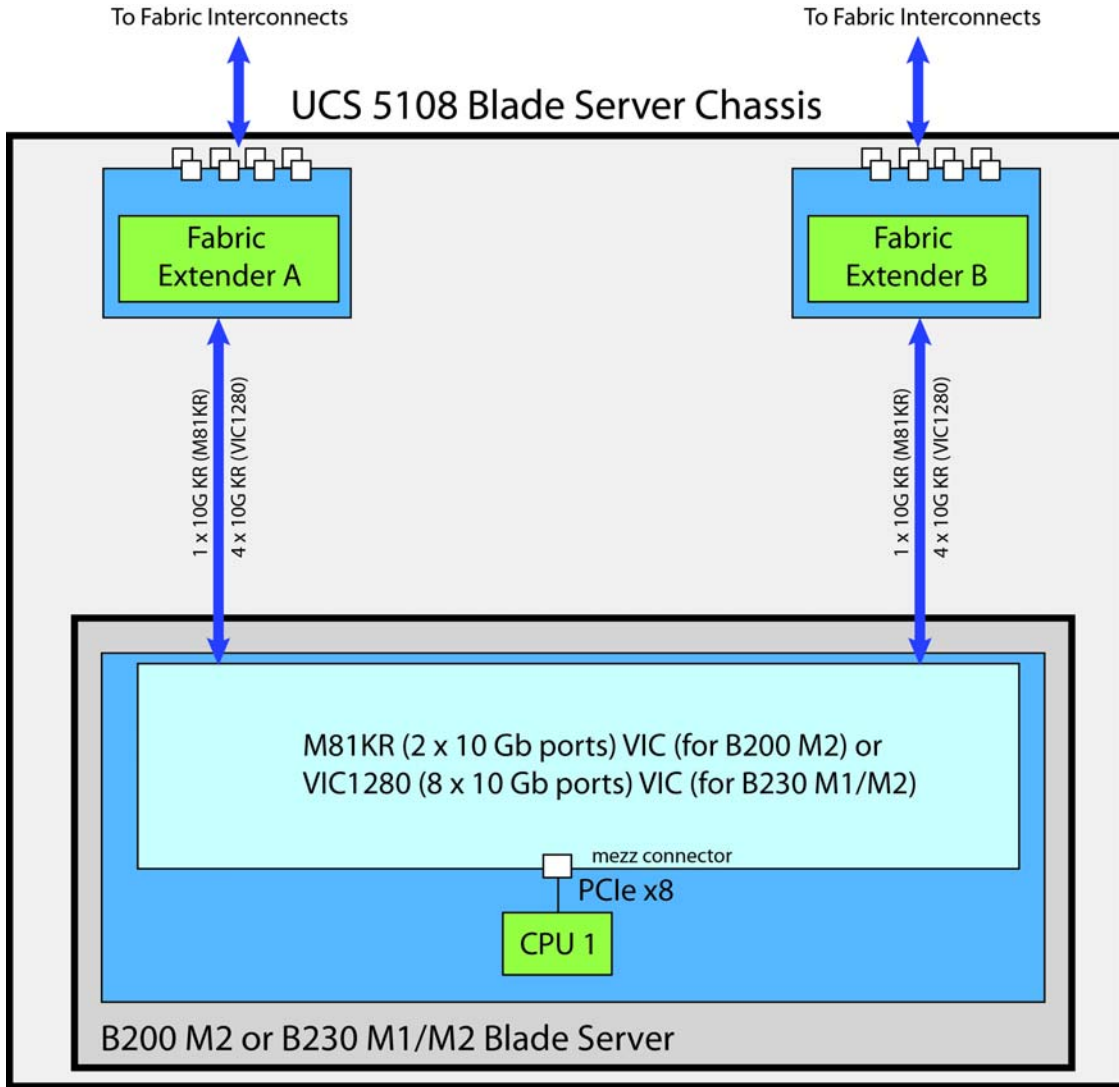

For the B200/B230 M1/M2 blade servers, supported card adapter combinations are shown in [Table 17](#).

Table 15 Adapter Card Options

Fabric Extender Compatibility	Adapter in Mezzanine Connector	Ports <sup>1</sup>
2208XP		
2208XP	M81KR	2 x 10 Gb
2208XP	VIC 1280 <sup>2</sup>	8 x 10 Gb
2208XP	Cisco-certified mezzanine adapter <sup>3</sup>	2 x 10 Gb
2204XP		
2204XP	M81KR	2 x 10 Gb
2204XP	VIC 1280 <sup>2</sup>	4 x 10 Gb
2204XP	Cisco-certified mezzanine adapter <sup>3</sup>	2 x 10 Gb
2104XP		
2104 XP	M81KR	2 x 10 Gb
2104 XP	VIC 1280 <sup>2</sup>	2 x 10 Gb
2104XP	Cisco-certified mezzanine adapter <sup>3</sup>	2 x 10 Gb

Notes . . .

1. Cisco-designed adapters are capable of port channeling. A port channel bundles up to four individual interfaces into a group to provide increased bandwidth and redundancy. Port channeling also load balances traffic across these physical interfaces. The port channel stays operational as long as at least one physical interface within the port channel is operational. Cisco-certified adapters supplied by third-party vendors do not support port channeling. Port channeling is indicated with an oval drawn around several individual ports.
2. Available only on M2 and M3 servers (not available on M1 servers)
3. Cisco-certified mezzanine adapters are manufactured by third-party vendors and are certified by Cisco for use in the servers. For more information about supported Cisco-certified mezzanine adapters, see [http://www.cisco.com/en/US/docs/unified\\_computing/ucs/hw/chassis/install/blade.html#wp1010426](http://www.cisco.com/en/US/docs/unified_computing/ucs/hw/chassis/install/blade.html#wp1010426)

The general connectivity diagrams between the mezzanine adapter cards and the different fabric extenders are shown in [Figure 9 on page 24](#) through [Figure 11 on page 25](#).

Figure 9 B200/B230 M1/M2 to 2208XP Fabric Extenders

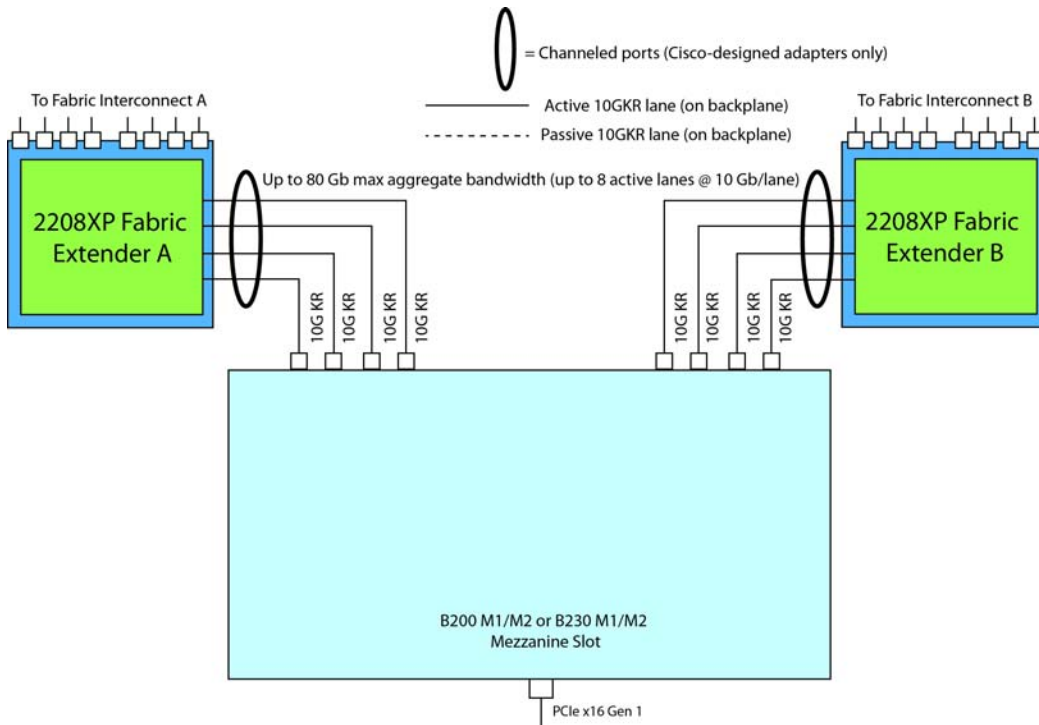

Figure 10 B200/B230 M1/M2 2204XP Fabric Extenders

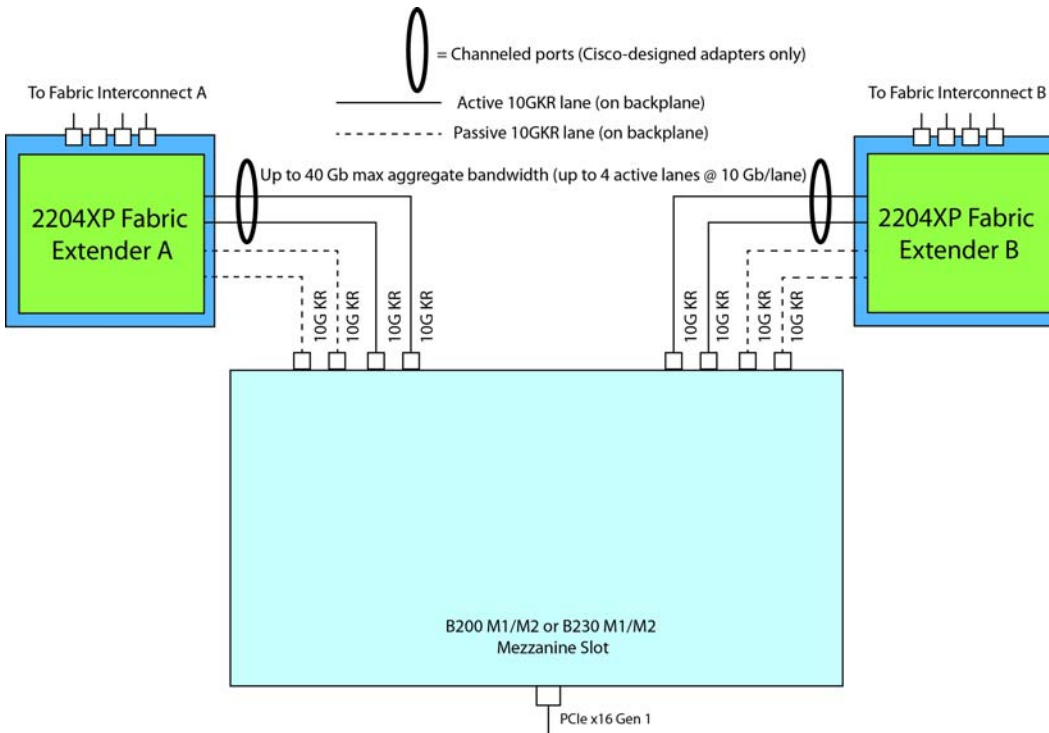
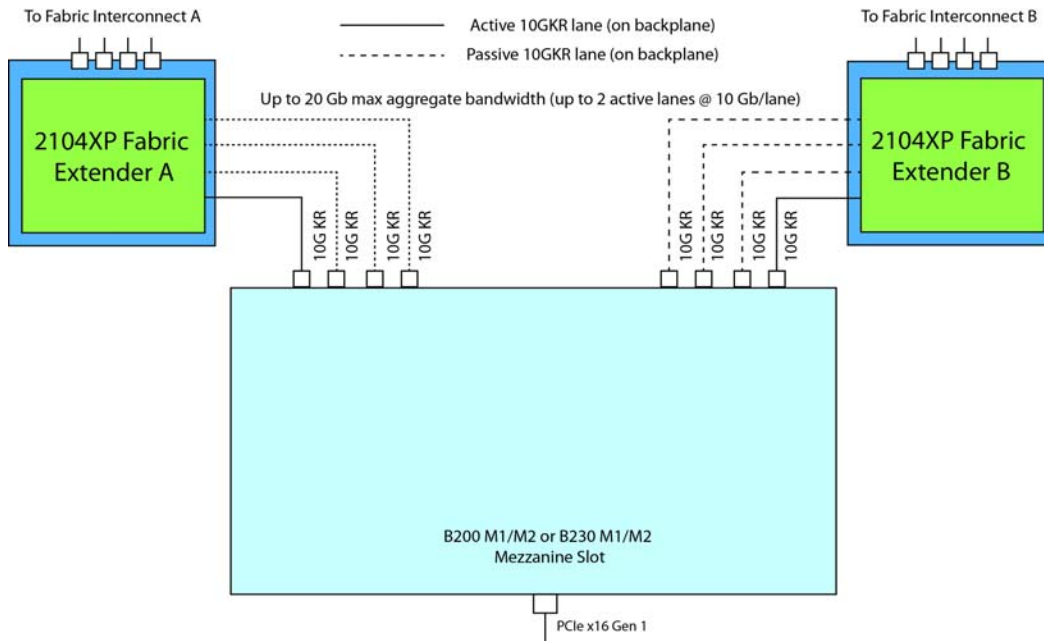



Figure 11 B200/B230 M1/M2 to 2104XP Fabric Extenders



### B250/B440 M1/M2 Connectivity (Full-Width Blades with Two Mezzanine Slots)

Figure 12 shows in general how the B250/B440 M1/M2 blade servers connect to the fabric extenders in the UCS 5108 chassis. Several cards are available for use in the two card adapter slots (see Table 16 on page 27). Note that adapter slot 0 is on the right when the server is viewed from the rear and slot 1 is on the left.

Figure 12 B250/B440 M1/M2 to Fabric Extenders

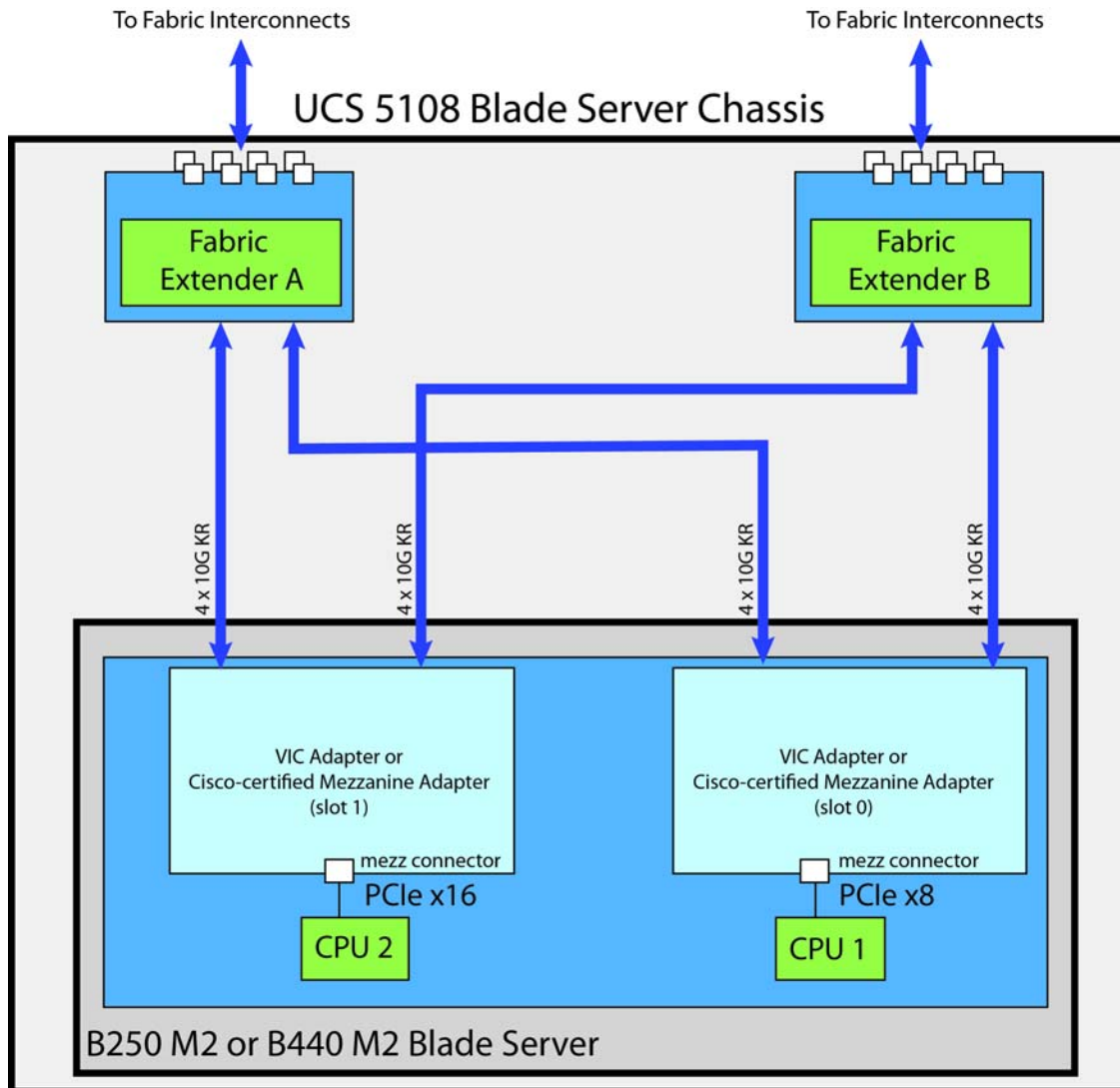

For the B250/B440 M1/M2 blade servers, supported card adapter combinations are shown in [Table 16](#).

Table 16 Adapter Card Options

Fabric Extender Compatibility	Adapter in Slot 0	Adapter in Slot 1	Ports <sup>1</sup>
<b>2208XP</b>			
2208XP	M81KR	Unoccupied	2 x 10 Gb
2208XP	Cisco-certified mezzanine adapter <sup>2</sup>	Unoccupied	2 x 10 Gb
2208XP	VIC 1280 <sup>3</sup>	Unoccupied	8 x 10 Gb
2208XP	M81KR	Cisco-certified mezzanine adapter	4 x 10 Gb
2208XP	Cisco-certified mezzanine adapter	M81KR	4 x 10 Gb
2208XP	VIC 1280 <sup>3</sup>	Cisco-certified mezzanine adapter	10 x 10 Gb
2208XP	Cisco-certified mezzanine adapter	VIC 1280 <sup>3</sup>	10 x 10 Gb
2208XP	Cisco-certified mezzanine adapter	Cisco-certified mezzanine adapter	4 x 10 Gb
<b>2204XP</b>			
2204XP	M81KR	Unoccupied	2 x 10 Gb
2204XP	VIC 1280 <sup>3</sup>	Unoccupied	4 x 10 Gb
2204XP	Cisco-certified mezzanine adapter	Unoccupied	2 x 10 Gb
2204XP	M81KR	Cisco-certified mezzanine adapter	4 x 10 Gb
2204XP	Cisco-certified mezzanine adapter	M81KR	4 x 10 Gb
2204XP	VIC 1280 <sup>3</sup>	Cisco-certified mezzanine adapter	6 x 10 Gb
2204XP	Cisco-certified mezzanine adapter	VIC 1280 <sup>3</sup>	6 x 10 Gb
2204XP	Cisco-certified mezzanine adapter	Cisco-certified mezzanine adapter	4 x 10 Gb
<b>2104XP</b>			
2104 XP	M81KR	Unoccupied	2 x 10 Gb
2104 XP	Cisco-certified mezzanine adapter	Unoccupied	2 x 10 Gb
2104 XP	VIC 1280 <sup>3</sup>	Unoccupied	2 x 10 Gb
2104 XP	M81KR	Cisco-certified mezzanine adapter	2 x 10 Gb
2104 XP	Cisco-certified mezzanine adapter	M81KR	2 x 10 Gb
2104 XP	VIC 1280 <sup>3</sup>	Cisco-certified mezzanine adapter	2 x 10 Gb
2104 XP	Cisco-certified mezzanine adapter	VIC 1280 <sup>3</sup>	2 x 10 Gb

Table 16 Adapter Card Options (continued)

Fabric Extender Compatibility	Adapter in Slot 0	Adapter in Slot 1	Ports <sup>1</sup>
2104XP	Cisco-certified mezzanine adapter	Cisco-certified mezzanine adapter	2 x 10 Gb

Notes . . .

1. Cisco-designed adapters are capable of port channeling. A port channel bundles up to four individual interfaces into a group to provide increased bandwidth and redundancy. Port channeling also load balances traffic across these physical interfaces. The port channel stays operational as long as at least one physical interface within the port channel is operational. Cisco-certified adapters supplied by third-party vendors do not support port channeling. Port channeling is indicated with an oval drawn around several individual ports.
2. Cisco-certified mezzanine adapters are manufactured by third-party vendors and are certified by Cisco for use in the servers. For more information about supported Cisco-certified mezzanine adapters, see [http://www.cisco.com/en/US/docs/unified\\_computing/ucs/hw/chassis/install/blade.html#wp1010426](http://www.cisco.com/en/US/docs/unified_computing/ucs/hw/chassis/install/blade.html#wp1010426)
3. Available only on M2 and M3 servers (not available on M1 servers)

The general connectivity diagrams between the adapter cards and the different fabric extenders are shown in [Figure 13 on page 28](#) through [Figure 15 on page 29](#).

Figure 13 B250/B440 M1/M2 to 2208XP Fabric Extenders

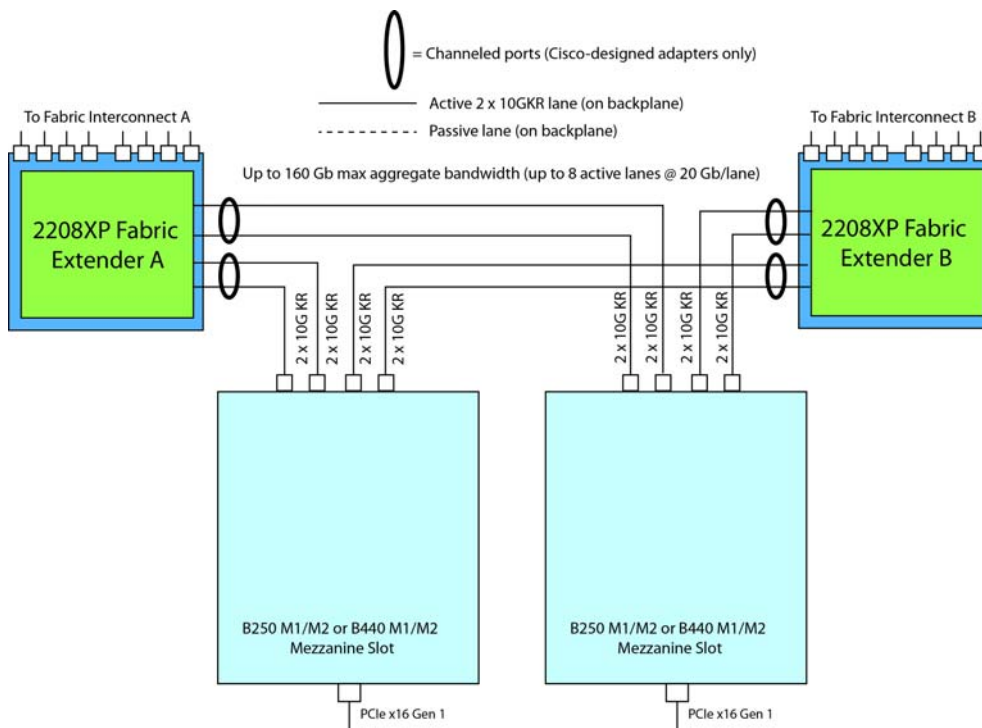

Figure 14 B250/B440 M1/M2 to 2204XP Fabric Extenders

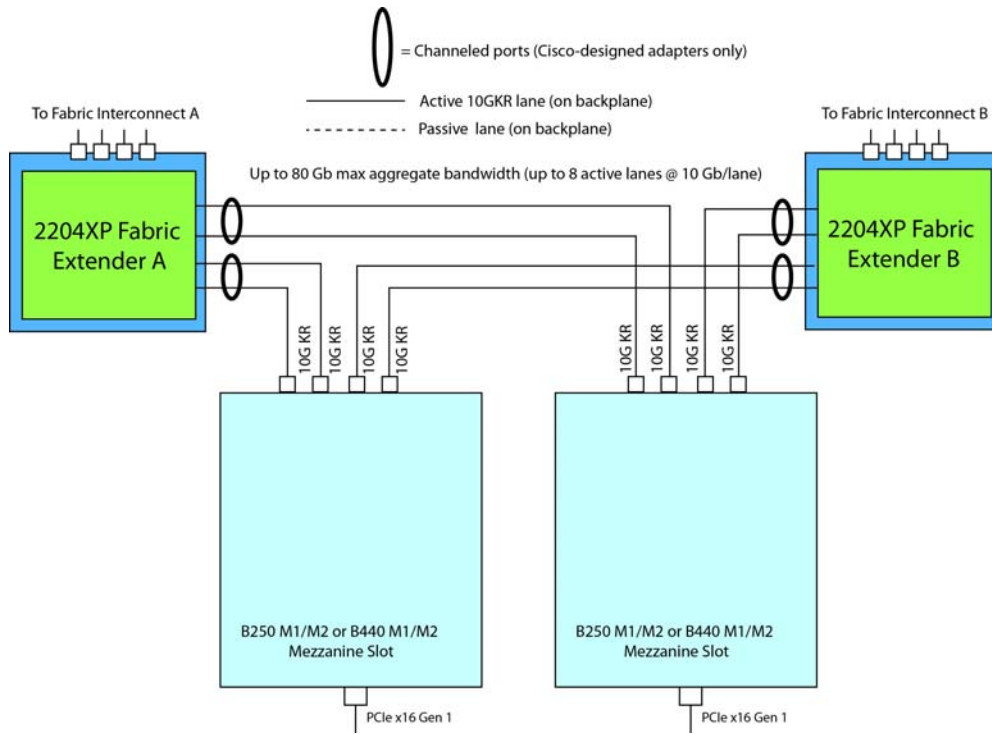
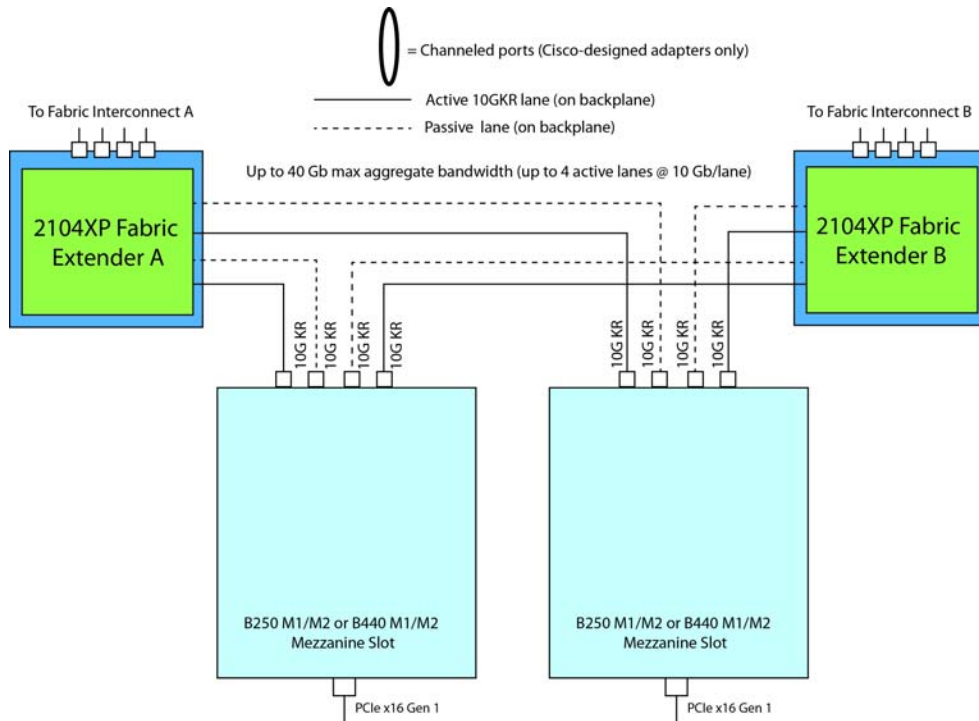

Figure 15 B250/B440 M1/M2 to 2104XP Fabric Extenders



### B22/B200 M3 Connectivity (Half-Width Blades with Two Mezzanine Slots)

Figure 16 shows in general how the B22 M3 and B200 M3 blade servers connect to the fabric extenders in the UCS 5108 chassis. Several cards are available for use in the two card adapter slots (see Table 19 on page 36 and Table 20 on page 37).

Figure 16 B22 M3 or B200 M3 to Fabric Extenders

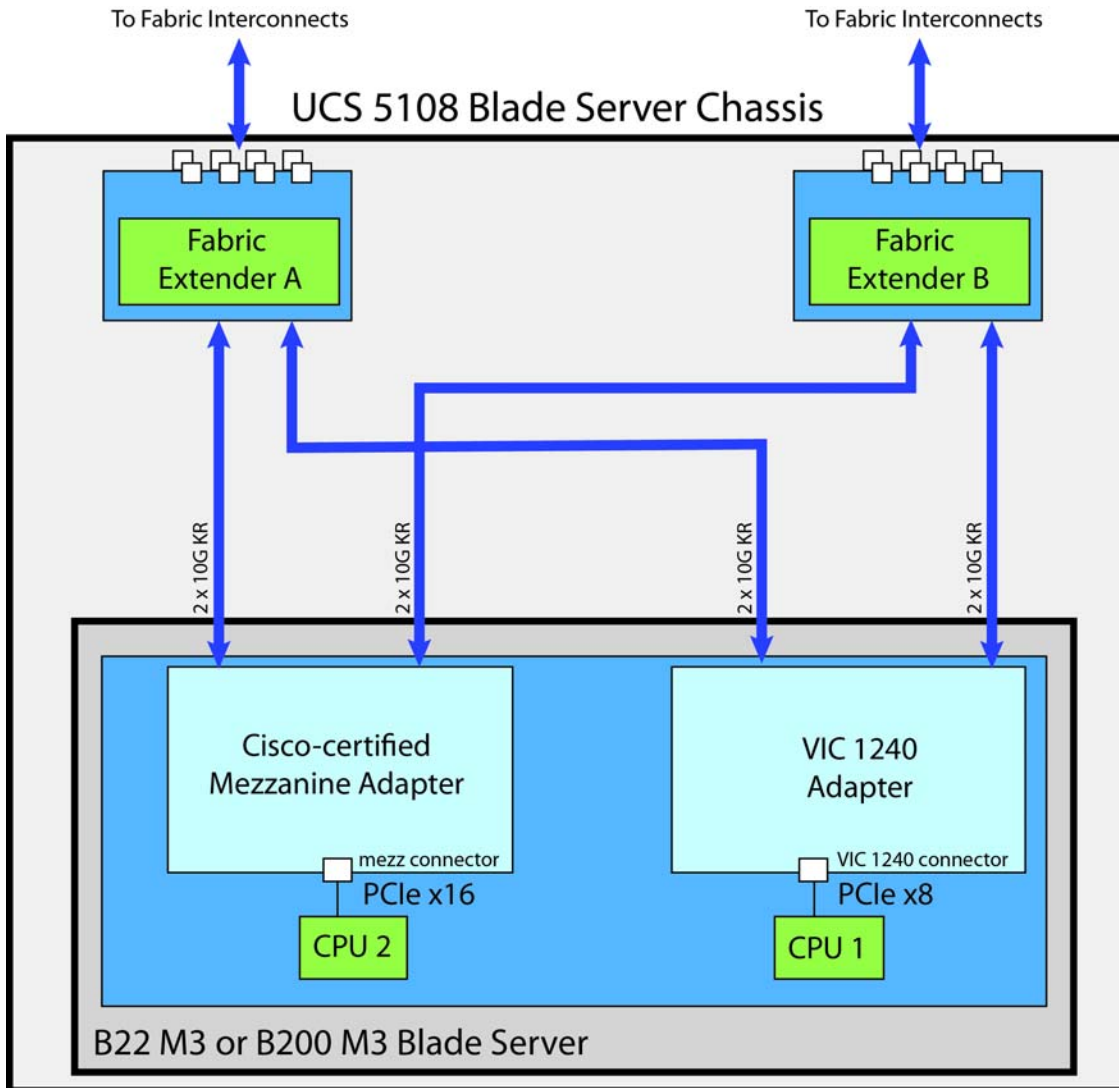

For the B22 M3 blade server, supported card adapter combinations are shown in [Table 17](#).

Table 17 Adapter Card Options

Fabric Extender Compatibility	Adapter in VIC 1240 Connector	Adapter in Mezzanine Connector	Ports <sup>1</sup>
<b>2208XP</b>			
2208XP	VIC 1240	None	4 x 10 Gb
2208XP	VIC 1240	VIC 1280	8 x 10 Gb
2208XP	VIC 1240	Cisco-certified mezzanine adapter <sup>2</sup>	6 x 10 Gb
2208XP	None	Cisco-certified mezzanine adapter	2 x 10 Gb
<b>2204XP</b>			
2204XP	VIC 1240	None	2 x 10 Gb
2204XP	VIC 1240	VIC 1280	4 x 10 Gb
2204XP	VIC 1240	Cisco-certified mezzanine adapter	4 x 10 Gb
2204XP	None	Cisco-certified mezzanine adapter	2 x 10 Gb
<b>2104XP</b>			
2104XP	VIC 1240	None <sup>3</sup>	2 x 10 Gb

Notes . . .

1. Cisco-designed adapters are capable of port channeling. A port channel bundles up to four individual interfaces into a group to provide increased bandwidth and redundancy. Port channeling also load balances traffic across these physical interfaces. The port channel stays operational as long as at least one physical interface within the port channel is operational. Cisco-certified adapters supplied by third-party vendors do not support port channeling. Port channeling is indicated with an oval drawn around several individual ports.
2. Cisco-certified mezzanine adapters are manufactured by third-party vendors and are certified by Cisco for use in the servers. For more information about supported Cisco-certified mezzanine adapters, see [http://www.cisco.com/en/US/docs/unified\\_computing/ucs/hw/chassis/install/blade.html#wp1010426](http://www.cisco.com/en/US/docs/unified_computing/ucs/hw/chassis/install/blade.html#wp1010426)
3. The 2104XP fabric extender is not compatible with any I/O card installed in the mezzanine connector.

For the B200 M3 blade server, supported card adapter combinations are shown in [Table 18](#).

Table 18 Adapter Card Options

Fabric Extender Compatibility	Adapter in VIC 1240 Connector	Adapter in Mezzanine Connector	Ports <sup>1</sup>
<b>2208XP</b>			
2208XP	VIC 1240	None	4 x 10 Gb
2208XP	VIC 1240	VIC 1280	8 x 10 Gb
2208XP	VIC 1240	Cisco-certified mezzanine adapter <sup>2</sup>	6 x 10 Gb
2208XP	VIC 1240	Port Expander Card for VIC 1240	8 x 10 Gb
2208XP	None	Cisco-certified mezzanine adapter	2 x 10 Gb
<b>2204XP</b>			
2204XP	VIC 1240	None	2 x 10 Gb
2204XP	VIC 1240	VIC 1280	4 x 10 Gb
2204XP	VIC 1240	Cisco-certified mezzanine adapter	4 x 10 Gb
2204XP	VIC 1240	Port Expander Card for VIC 1240	4 x 10 Gb
2204XP	None	Cisco-certified mezzanine adapter	2 x 10 Gb
<b>2104XP</b>			
2104XP	VIC 1240	None <sup>3</sup>	2 x 10 Gb

Notes . . .

1. Cisco-designed adapters are capable of port channeling. A port channel bundles up to four individual interfaces into a group to provide increased bandwidth and redundancy. Port channeling also load balances traffic across these physical interfaces. The port channel stays operational as long as at least one physical interface within the port channel is operational. Cisco-certified adapters supplied by third-party vendors do not support port channeling. Port channeling is indicated with an oval drawn around several individual ports.
2. Cisco-certified mezzanine adapters are manufactured by third-party vendors and are certified by Cisco for use in the servers. For more information about supported Cisco-certified mezzanine adapters, see [http://www.cisco.com/en/US/docs/unified\\_computing/ucs/hw/chassis/install/blade.html#wp1010426](http://www.cisco.com/en/US/docs/unified_computing/ucs/hw/chassis/install/blade.html#wp1010426)
3. The 2104XP fabric extender is not compatible with any I/O card installed in the mezzanine connector.

The general connectivity diagrams between the adapter cards and the different fabric extenders are shown in [Figure 17 on page 33](#) through [Figure 19 on page 34](#).



Figure 17 B22/B200 M3 to 2208XP Fabric Extenders

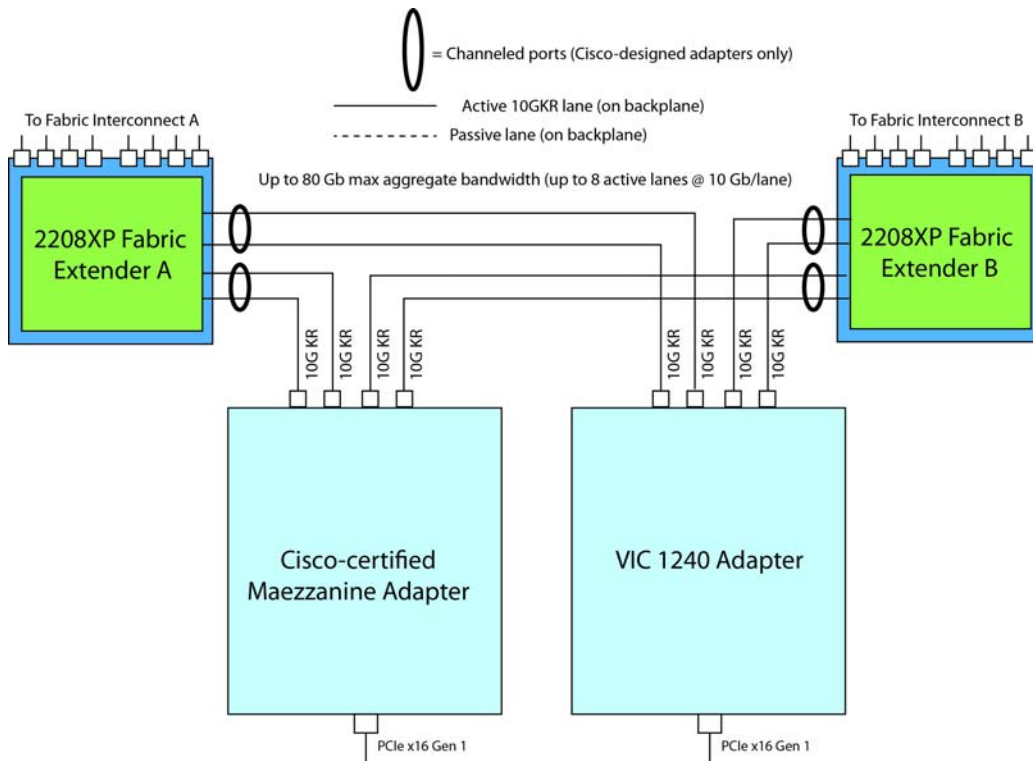

Figure 18 B22/B200 M3 to 2204XP Fabric Extenders

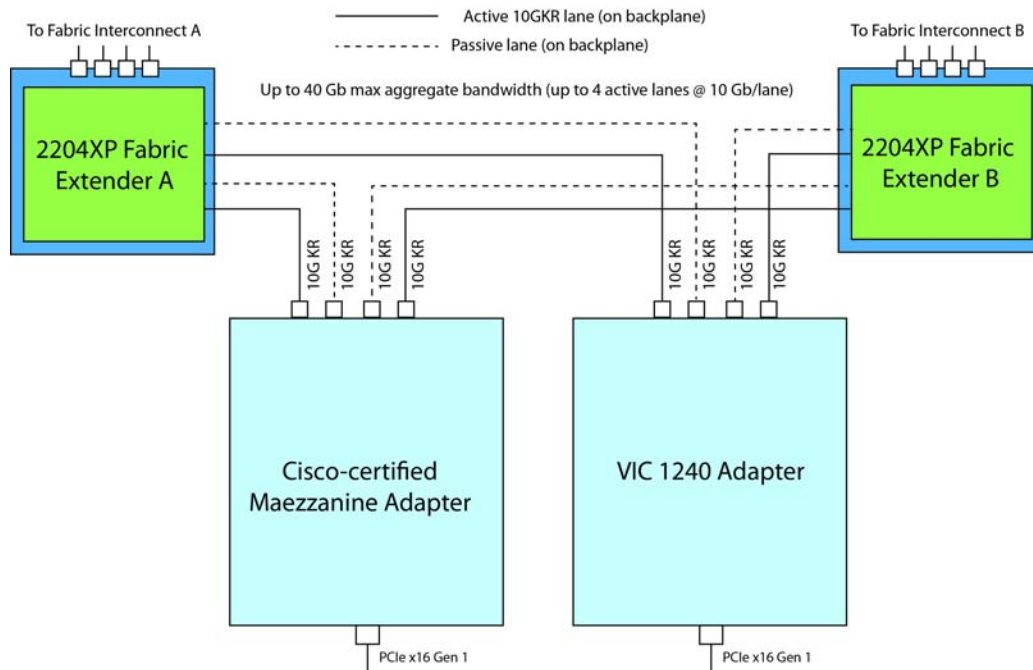
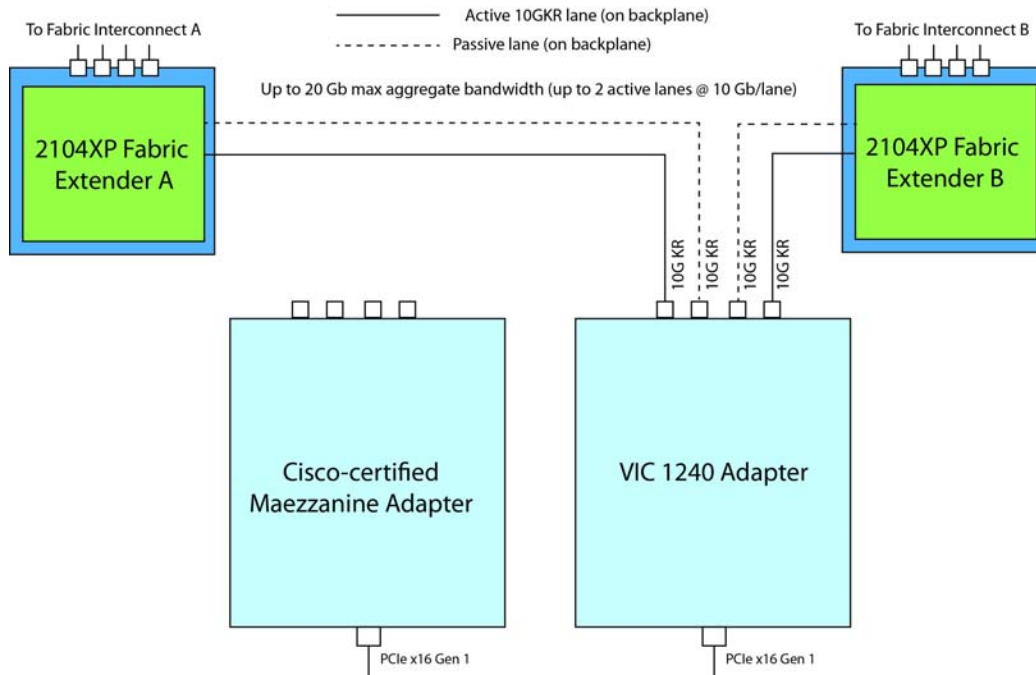

Figure 19 B22/B200 M3 to 2104XP Fabric Extenders



### B420 M3 Connectivity (Full-Width Blade with Three Mezzanine Slots)

Figure 20 shows in general how the B420 M3 blade server connects to the fabric extenders in the UCS 5108 chassis. Several cards available for use in the three adapter card slots (see Table 19 on page 36 and Table 20 on page 37).

Figure 20 B420 M3 to Fabric Extenders

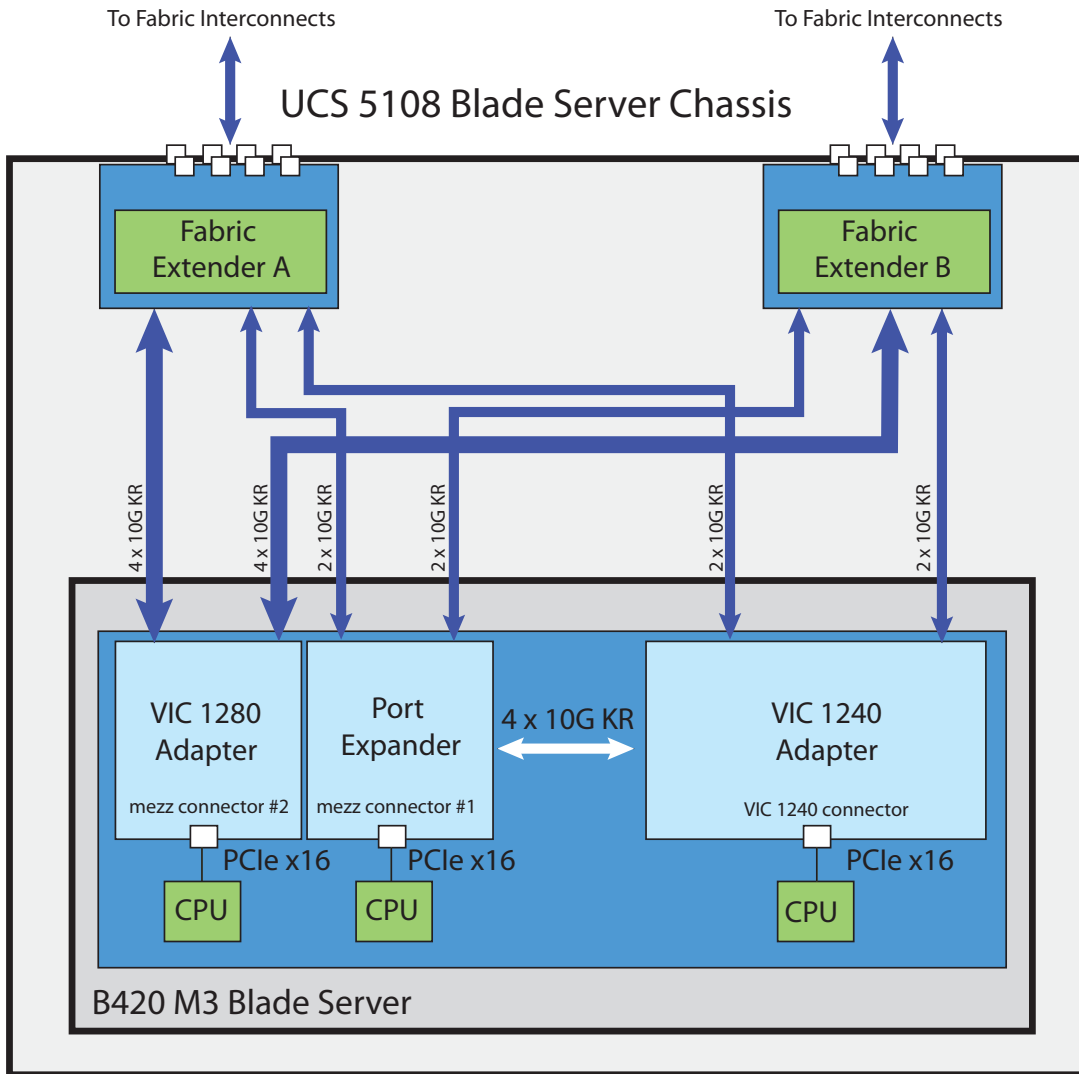

Supported 4-CPU card adapter combinations are shown in [Table 19](#).

Table 19 Supported Mezzanine Adapter Combinations (4-CPU Configuration)

Adapter in VIC 1240 Connector	Adapter in Mezzanine Slot 1	Adapter in Mezzanine Slot 2	Total Available Bandwidth <sup>1</sup>		
			2 x 2208 XP	2 x 2204 XP	2 x 2104 XP
VIC 1240	Not populated	Not populated	40 Gb	20 Gb	20 Gb
VIC 1240	Not populated	VIC 1280	120 Gb	60 Gb	40 Gb
Not populated	Not populated	VIC 1280	80 Gb	40 Gb	20 Gb
VIC 1240	Not populated	Cisco-certified mezzanine adapter <sup>2</sup>	60 Gb	40 Gb	40 Gb
VIC 1240	Port Expander Card for VIC 1240	Not populated	80 Gb	40 Gb	Not supported <sup>3</sup>
Not populated	Not populated	Cisco-certified mezzanine adapter	20 Gb	20 Gb	20 Gb
Not populated	Cisco-certified mezzanine adapter	Cisco-certified mezzanine adapter	40 Gb	40 Gb	Not supported <sup>3</sup>
VIC 1240	Port Expander Card for VIC 1240	VIC 1280	160 Gb	80 Gb	Not supported <sup>3</sup>

Notes . . .

1. Cisco-designed adapters are capable of port channeling. A port channel bundles up to four individual interfaces into a group to provide increased bandwidth and redundancy. Port channeling also load balances traffic across these physical interfaces. The port channel stays operational as long as at least one physical interface within the port channel is operational. Cisco-certified adapters supplied by third-party vendors do not support port channeling. Port channeling is indicated with an oval drawn around several individual ports.
2. Cisco-certified mezzanine adapters are manufactured by third-party vendors and are certified by Cisco for use in the servers. For more information about supported Cisco-certified mezzanine adapters, see [http://www.cisco.com/en/US/docs/unified\\_computing/ucs/hw/chassis/install/blade.html#wp1010426](http://www.cisco.com/en/US/docs/unified_computing/ucs/hw/chassis/install/blade.html#wp1010426)
3. The 2104XP fabric extender is not compatible with any I/O card installed in mezzanine connector 1.

Supported 2-CPU card adapter combinations are shown in [Table 20](#).

Table 20 Supported Mezzanine Adapter Combinations (2-CPU Configuration)

Adapter in VIC 1240 Connector	Adapter in Mezzanine Slot 1	Adapter in Mezzanine Slot 2	Total Available Bandwidth <sup>1</sup>		
			2 x 2208XP	2 x 2204 XP	2 x 2104 XP
VIC 1240	Not populated	Not populated	40 Gb	20 Gb	20 Gb
VIC 1240	Not populated	VIC 1280	120 Gb	60 Gb	40 Gb
VIC 1240	Not populated	Cisco-certified mezzanine adapter <sup>2</sup>	60 Gb	40 Gb	40 Gb
VIC 1240	Port Expander Card for VIC 1240 <sup>3</sup>	Not populated	80 Gb	40 Gb	Not supported <sup>4</sup>
Not populated	Not populated	Cisco-certified mezzanine adapter	20 Gb	20 Gb	20 Gb
VIC 1240	Port Expander Card for VIC 1240 <sup>3</sup>	VIC 1280	160 Gb	80 Gb	Not supported <sup>4</sup>

Notes . . .

1. Cisco-designed adapters are capable of port channeling. A port channel bundles up to four individual interfaces into a group to provide increased bandwidth and redundancy. Port channeling also load balances traffic across these physical interfaces. The port channel stays operational as long as at least one physical interface within the port channel is operational. Cisco-certified adapters supplied by third-party vendors do not support port channeling. Port channeling is indicated with an oval drawn around several individual ports.
2. Cisco-certified mezzanine adapters are manufactured by third-party vendors and are certified by Cisco for use in the servers. For more information about supported Cisco-certified mezzanine adapters, see [http://www.cisco.com/en/US/docs/unified\\_computing/ucs/hw/chassis/install/blade.html#wp1010426](http://www.cisco.com/en/US/docs/unified_computing/ucs/hw/chassis/install/blade.html#wp1010426)
3. Only the Port Expander for VIC 1240 is functional in mezzanine slot 1 in 2-CPU configurations
4. The 2104XP fabric extender is not compatible with any adapter installed in mezzanine slot 1

The general connectivity diagrams between the card adapters and the different fabric extenders are shown in [Figure 21 on page 38](#) through [Figure 23 on page 39](#).

Figure 21 B420 M3 to 2208XP Fabric Extenders

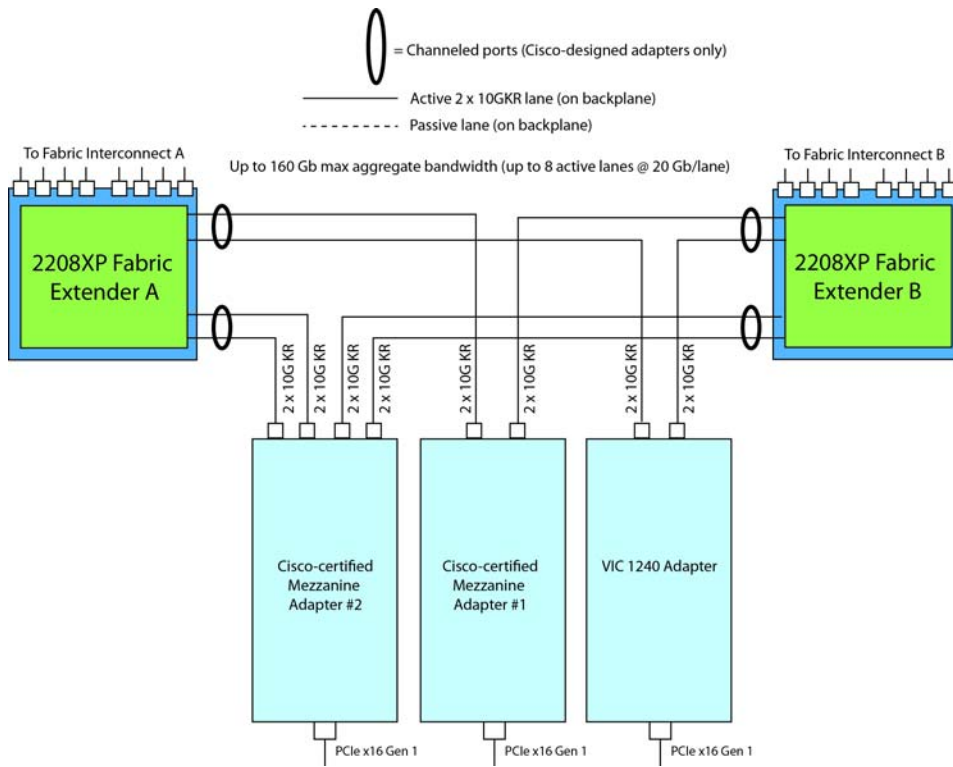

Figure 22 B420 M3 to 2204XP Fabric Extenders

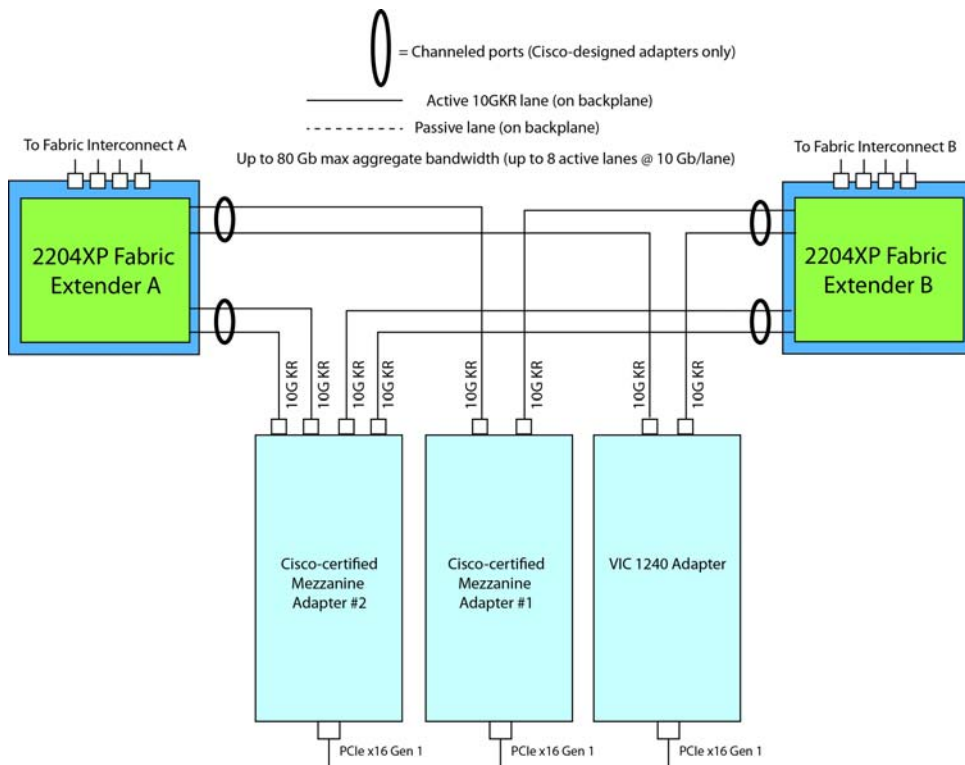
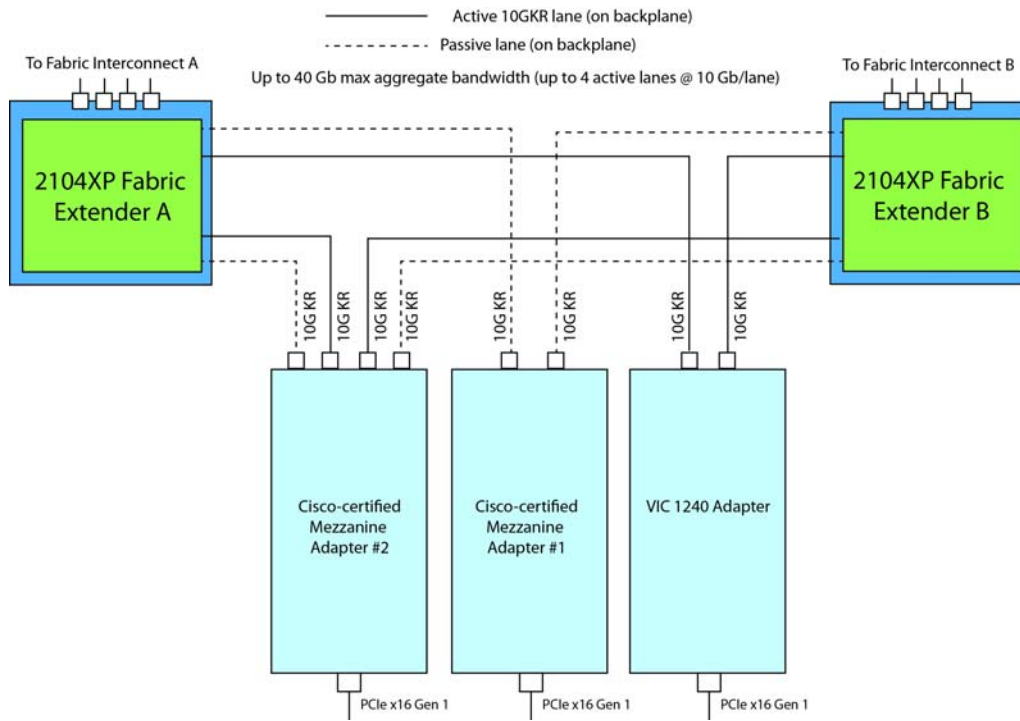

Figure 23 B420 M3 to 2104XP Fabric Extenders



## Connectivity Between Fabric Extender and Fabric Interconnect

Figure 24 shows the correct method to connect the Fabric Interconnect modules to two separate port fabric interconnects. You must connect each port fabric interconnect to the chassis through its own Fabric Extender.

Figure 24 Connecting Blade Chassis Fabric Extenders to Fabric Interconnect Chassis

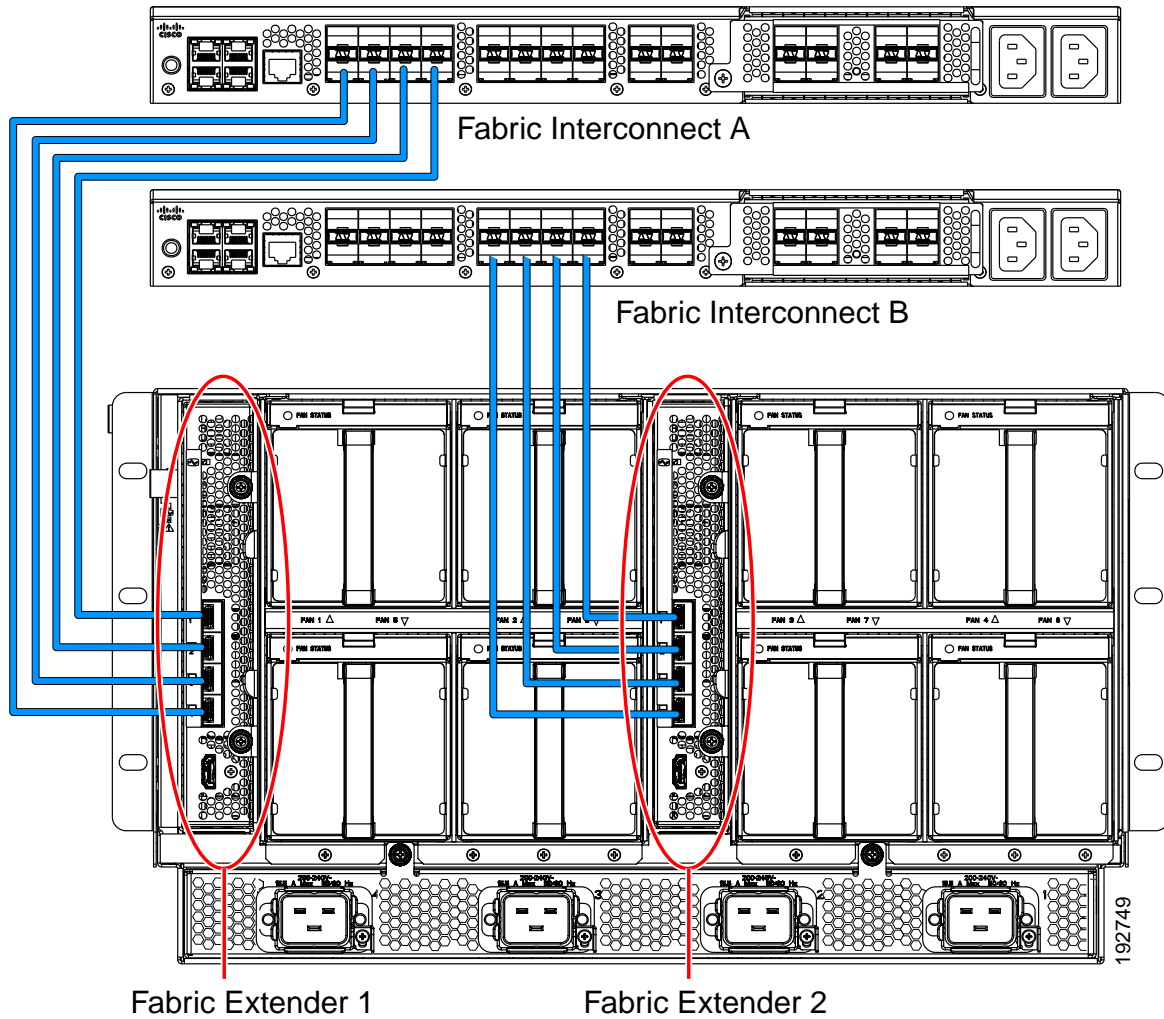



## SFP+ Transceivers

Each Cisco Fabric Extender within the chassis supports Small Form-Factor Pluggable (SFP+) copper or optical transceivers. Each transceiver runs at 10 Gbs.

### Copper SFP+ Twinax Transceivers

The Cisco Fabric Extenders support Twinax copper transceivers with twinax cables of various lengths. The assembly consists of two transceivers connected by a twinax copper cable. The enhanced SFP+ 10-Gb Ethernet transceiver is a bidirectional device with a transmitter and receiver in the same physical package. It has a 20-pin connector on the electrical interface.

*Figure 25* shows the SFP-H10GB-CU5M transceiver. The rubber loop is used for removing the SFP+ from its port on the I/O module.

Figure 25 SFP+ 10 Gb Twinax Copper Transceiver

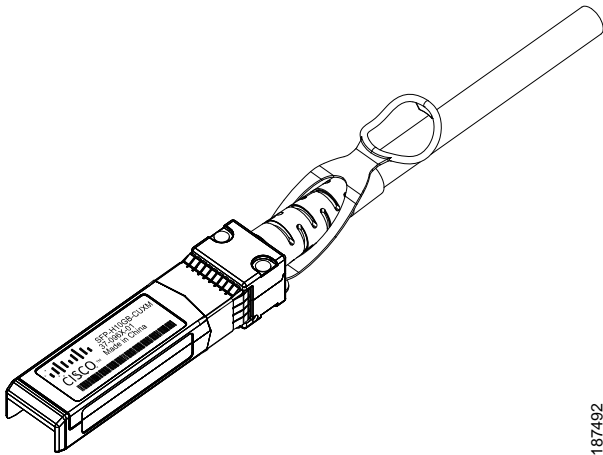

187492

## Optical SFP+ Transceivers

If distances greater than 5 meters (16.4 feet) must be spanned, the Fabric Extender supports the substitution of the copper SFP+ by optical SFP+ transceivers. The SFP+ 10-Gb Ethernet optical transceiver is a bidirectional device with a transmitter and receiver in the same physical package, as shown in [Figure 26](#). It has a duplex LC connector on the optical interface. A fiber optic cable must be used to connect the two transceivers together.

Figure 26 SFP+ Optical Transceiver

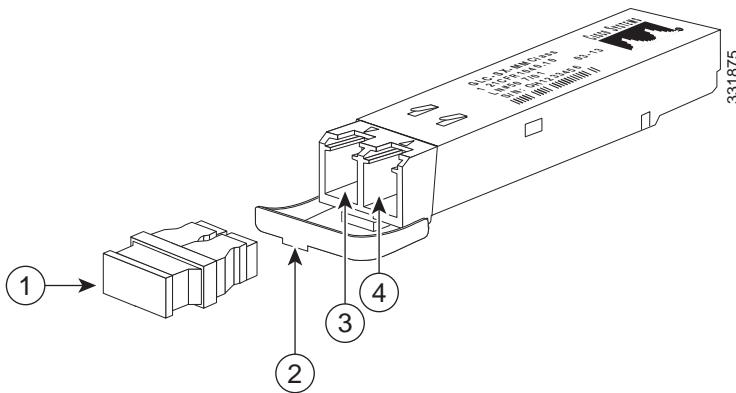

Table 21 SFP+ Callouts

Callout	Description
1	Dust plug
2	Bail clasp with clasp tab
3	Transmit bore
4	Receive bore

## Fabric Extender Bundles

You can order two kinds of Fabric Extender bundles:

- UCS-IOM2208-16FET. This bundle includes one 2208XP Fabric Extender plus 16 Fabric Extender Transceivers (FETs). 8 FETs are used for the Fabric Extender and 8 for the Fabric Interconnect.
- UCS-IOM2204-8FET. This bundle includes one 2204XP Fabric Extender plus 16 Fabric Extender Transceivers (FETs). 4 FETs are used for the Fabric Extender and 4 for the Fabric Interconnect.

The FETs are in an SFP+ form-factor and support 10 Gbps full-duplex transmissions between the Fabric Extender and Fabric Interconnect, using your own multimode fiber (MMF) optical cables. The reach is 25 meters using OM2 MMF optical cables and 100 meters using OM3 MMF optical cables.

If you do not order the bundle that includes the transceivers, you can order the transceivers separately as spares (PID = FET-10G=).

# TECHNICAL SPECIFICATIONS

## Physical Dimensions and Specifications

Table 22 Cisco UCS 5108 Chassis Specifications

Parameter	Value
Height	10.5 in. (26.7 cm); 6 rack unit (6RU)
Width	17.5 in. (44.5 cm); fits standard 19-inch square-hole rack (or round hole threaded or non-threaded, with optional adapter kit)
Depth	32 in. (81.2 cm)
Weight	90 lbs (40.83 kg) empty, 255 lbs (115.66 kg) fully configured
Blade server slots	8 half-width slots, 4 full-width slots, or combination of half- and full-width slots.
Fabric Extender slots	2
Fabric Extenders	Compatible with 2208XP, 2204XP, and 2104XP Fabric Extenders
Power	Four 2500 W output, 200 V - 240 V, 50 to 60 Hz, single-phase, hot-swappable, redundant power supplies, with IEC-320 C20 connections or 2500 W output -48 V DC Input  Supports non-redundant, N+1 redundant, and N+N grid redundant configurations
Fans	8 hot-swappable fans  Each fan module contains 2 redundant fans; up to two fans can fail in the system.
Management	Managed from the Cisco UCS 6100/6200 Series Fabric Interconnects by Cisco UCS Manager (redundant management operations when the chassis is configured with two fabric extenders)
Backplane	1.2 TB of aggregate throughput; supports 10BASE-KR connections for 8 blades
Regulatory compliance	Products comply with CE Markings per directives 2004/108/EC and 2006/108/EC
Safety	<ul style="list-style-type: none"> <li>■ UL 60950-1</li> <li>■ CAN/CSA-C22.2 No. 60950-1</li> <li>■ EN 60950-1</li> <li>■ IEC 60950-1</li> <li>■ AS/NZS 60950-1</li> <li>■ GB4943</li> </ul>

Table 22 Cisco UCS 5108 Chassis Specifications *(continued)*

Parameter	Value
EMC: Emissions	<ul style="list-style-type: none"> <li>■ 47CFR Part 15 (CFR 47) Class A</li> <li>■ AS/NZS CISPR22 Class A</li> <li>■ CISPR2 2 Class A</li> <li>■ EN55022 Class A</li> <li>■ ICES003 Class A</li> <li>■ VCCI Class A</li> <li>■ EN61000-3-2</li> <li>■ EN61000-3-3</li> <li>■ KN22 Class A</li> </ul>
EMC: Immunity	<ul style="list-style-type: none"> <li>■ EN50082-1</li> <li>■ EN61000-6-1</li> <li>■ EN55024</li> <li>■ CISPR24</li> <li>■ EN300386</li> <li>■ KN 61000-4 Series</li> </ul>

## Power Specifications

The specifications for the various 5108 blade chassis power supplies are listed in [Table 23](#) through [Table 25](#).

Table 23 AC Input Gold Power Supply (N20-PAC5-2500W) Specifications

Description	Specification
AC-input voltage	200 to 240 VAC nominal (Range: 180 to 264 VAC)
AC-input frequency	50 to 60 Hz nominal (Range: 47 to 63 Hz)
AC-input current	15.5 Amps @ 200 VAC
Maximum Input VA	2790 VA @ 200 VAC
Maximum output power per power supply	2500 W @ 200 to 240 VAC
Maximum inrush current	35 A (sub cycle duration)
Maximum hold up time	12 ms @ 2500 W
Power supply output voltage	12 VDC @ 208 V
Efficiency rating	Climate Savers Gold

Table 23 AC Input Gold Power Supply (N20-PAC5-2500W) Specifications *(continued)*

Description	Specification			
Efficiency (80Plus Gold Certified)	10% load	20% load	50% load	100% load
	88.61%	91.64%	92.21%	90.97%
Input Connector	IEC320 C20			

Table 24 AC Input Platinum Power Supply (UCSB-PSU-2500ACPL) Specifications

Description	Specification			
AC-input voltage	200 to 240 VAC nominal (Range: 180 to 264 VAC)			
AC-input frequency	50 to 60 Hz nominal (Range: 47 to 63 Hz)			
AC-input current	< 16 Amps @ 200 VAC			
Maximum Input VA	2790 VA @ 200 VAC			
Maximum output power per power supply	2500 W @ 200 to 240 VAC (up to four power supplies)			
Maximum inrush current	35 A (sub cycle duration)			
Maximum hold up time	12 ms @ 2500 W			
Power supply output voltage	12 VDC			
Power supply standby voltage	3.3 VDC			
Efficiency rating	Climate Savers Platinum			
Efficiency (80Plus Platinum Certified)	10% load	20% load	50% load	100% load
	89.63%	93.25%	94.19%	92.07%
Input Connector	IEC320 C20			

Table 25 DC Input Power Supply (UCSB-PSU-2500DC48) Specifications

Description	Specification			
Minimum software requirement	Cisco UCS Manager Release 2.0(1) Capability Catalog Version 42			
DC input voltage	-48 VDC to -60 VDC nominal (range: -40 to -72 VDC)			
Maximum output power per power supply	2500 W			
Maximum inrush current	35 A (sub cycle duration)			
Current draw at min voltage	62 A			
Current draw at max voltage	50 A			
Maximum input VA	2880			
Efficiency	10% load	20% load	50% load	100% load
	88.73%	91.68%	92.19%	90.51%
DC input terminal block	Accepts Panduit LCD4-14AF-L or equivalent barrel-type lug terminals with 90-degree angle, two-hole tongue, which accommodates 1/0 AWG size copper wire. The connector tongue width is 0.82 in, the stud hole spacing is 5/8 in, and the hole size is 1/4 in.			
Maximum hold up time	8 ms			

For configuration-specific power specifications, use the Cisco UCS Power Calculator at:

<https://express.salire.com/Go/Cisco/Cisco-UCS-Power-Calculator.aspx>

## Environmental Specifications

The environmental specifications for the 5108 blade chassis are listed in [Table 26](#).

Table 26 UCS 5108 Blade Server Environmental Specifications

Parameter	Minimum
Temperature operating	10° C to 35° C (50° F to 95° F)
Temperature nonoperating	-40° C to 65° C (-40° F to 149° F)
Altitude operating	0 to 3, 000 m (0 to 10,000 ft.); maximum ambient temperature decreases by 1° per 300 m
Humidity operating	10 to 90%, non-condensing
Humidity nonoperating	5 to 93%, non-condensing
Vibration nonoperating	2.2 Grms, 10 minutes per axis on each of the three axes
Shock operating	Half-sine 2 G, 11 ms pulse, 100 pulses in each direction, on each of the three axes
Shock nonoperating	Trapezoidal, 25 G, two drops on each of six faces $\Delta V$ : 175 inches per second each corner on bottom face drop, 90 inches per second each corner on other five faces
Safety	UL60 950-1 No. 21CFR1040, CAN/CSA-C22.2 No. 60950-1, IRAM IEC60950-1, CB IEC60950-1, EN 60950-1, IEC 60950-1, GOST IEC60950-1, SABS/CB IEC6095-1, CCC*/CB GB4943-1995, CNS14336, CB IEC60950-1, AS/NZS 60950-1, GB4943
Emissions	47CFR Part 15 (CFR 47) Class A, AS/NZS CISPR22 Class A, CISPR2 2 Class A, EN55022 Class A, ICES003 Class A, VCCI Class A, EN61000-3-2, EN61000-3-3, KN22 Class A, CNS13438 Class A
Immunity	Verified to comply with EN55024, CISPR 24, KN 61000-4 Series, KN 24
Electrostatic discharge	Tested to ESD levels up to 15 kilovolts (kV) air discharge and up to 8 kV contact discharge without physical damage
Acoustic	<ul style="list-style-type: none"> <li>■ Sound power: 68.8 dBA at ambient temperature 23° C measured using the Dome Method</li> <li>■ GOST MsanPiN 001-96</li> </ul>



---

**Americas Headquarters**  
Cisco Systems, Inc.  
San Jose, CA

**Asia Pacific Headquarters**  
Cisco Systems (USA) Pte. Ltd.  
Singapore

**Europe Headquarters**  
Cisco Systems International BV Amsterdam,  
The Netherlands

Cisco has more than 200 offices worldwide. Addresses, phone numbers, and fax numbers are listed on the Cisco Website at [www.cisco.com/go/offices](http://www.cisco.com/go/offices).

Cisco and the Cisco Logo are trademarks of Cisco Systems, Inc. and/or its affiliates in the U.S. and other countries. A listing of Cisco's trademarks can be found at [www.cisco.com/go/trademarks](http://www.cisco.com/go/trademarks). Third party trademarks mentioned are the property of their respective owners. The use of the word partner does not imply a partnership relationship between Cisco and any other company. (1005R)