

PowerEdge R415



Technical Guide



The PowerEdge R415 offers enterprise-class features with a balance of processing power and value.

This document is for informational purposes only. Dell reserves the right to make changes without further notice to any products herein. The content provided is as is and without express or implied warranties of any kind.

Dell, PowerEdge, OpenManage, and ReadyRails are trademarks of Dell, Inc. AMD, AMD Opteron, AMD PowerNow!, CoolCore, and combinations thereof are trademarks of Advanced Micro Devices, Inc. Citrix® and XenServer™ are trademarks of Citrix Systems, Inc. and/or one or more of its subsidiaries, and may be registered in the United States Patent and Trademark Office and in other countries. Intel and Xeon are registered trademarks of Intel Corporation in the U.S. and other countries. Broadcom is a registered trademark of Broadcom Corporation and/or its affiliates in the United States, certain other countries and/or the EU. Matrox is a registered trademark of Matrox Electronic Systems Ltd. Microsoft, Windows, Windows Server, SQL Server, BitLocker, and Hyper-V are either registered trademarks or trademarks of Microsoft Corporation in the United States and/or other countries. Nuvoton is a registered trademark of Nuvoton Technology Corporation. Red Hat is a registered trademark of Red Hat, Inc. in the United States and other countries. Linux is a registered trademark of Linus Torvalds. QLogic is a registered trademark of QLogic Corporation. VMware and ESX are registered trademarks and vSphere and ESXi are trademarks of VMware, Inc. in the United States and/or other jurisdictions. Other trademarks and trade names may be used in this document to refer to either the entities claiming the marks and names or their products. Dell disclaims proprietary interest in the marks and names of others.

©Copyright 2010-2011 Dell Inc. All rights reserved. Reproduction or translation of any part of this work beyond that permitted by U.S. copyright laws without the written permission of Dell Inc. is unlawful and strictly forbidden.

Revision 1 May 2011

Table of Contents

1	Product Comparison	7
1.1	Overview	7
1.1.1	Designed to Go the Distance	7
1.1.2	Efficient from the Inside Out	7
1.1.3	Easy to Manage.....	7
1.2	Comparison	8
2	System Overview.....	11
3	Mechanical	14
3.1	Chassis Description	14
3.2	Dimensions and Weight	14
3.3	Front Panel View and Features.....	15
3.4	Back Panel View and Features.....	15
3.5	Power Supply Indicators	16
3.6	NIC Indicators	16
3.7	Side Views	16
3.8	Internal Chassis View	17
3.9	Rails and Cable Management	17
3.9.1	ReadyRails Sliding Rails	17
3.9.2	ReadyRails Static Rails	17
3.10	Rack View.....	18
3.10.1	Sliding Rails.....	18
3.10.2	Static Rails.....	18
3.11	Fans.....	19
3.12	Control Panel.....	19
3.12.1	LED Panel Configuration	20
3.12.2	LCD Panel Configuration.....	20
3.13	Security	21
3.13.1	Cover Latch.....	21
3.13.2	Bezel.....	21
3.13.3	Hard Drive	21
3.13.4	Trusted Platform Module (TPM)	21
3.13.5	Power Off Security	21
3.13.6	Intrusion Alert.....	21
3.13.7	Secure Mode.....	22
3.14	USB Key	22
3.15	Battery	22
3.16	Field Replaceable Units (FRU)	22
3.17	User Accessible Jumpers, Sockets, and Connectors	22
4	Power, Thermal, Acoustic	23
4.1	Power Supplies.....	23
4.2	Power Supply Specifications	23
4.3	Heat Dissipation	24
4.4	Environmental Specifications	24
4.5	ENERGY STAR® Compliance	25
4.6	Thermal	25
4.7	Acoustics.....	25
5	Processors.....	27
5.1	Overview.....	27

Dell	
5.2	Features 27
5.3	Supported Processors 27
5.4	Processor Configurations 28
5.5	Processor Installation 28
6	Memory 29
6.1	Overview 29
6.2	DIMMs Supported 29
6.3	DIMM Slots 29
6.4	Speed 30
6.5	Sparing 30
6.6	Mirroring 30
6.7	RAID 30
6.8	Supported Configurations 30
7	Chipset 32
7.1	Overview 32
7.2	AMD I/O Bridges 32
7.3	HyperTransport 3 (HT3) 32
7.4	Southbridge Link Interface 32
7.5	AMD SP5100 Southbridge (SP5100) 32
8	BIOS 33
8.1	Overview 33
8.2	Supported ACPI States 34
8.3	Power Management Modes 34
8.3.1	Dell Active Power Controller 34
8.3.2	Power Saving BIOS Setting (OS Control) 34
8.3.3	Maximum Performance 34
9	Embedded NICs/LAN on Motherboard (LOM) 37
10	I/O Slots 38
10.1	Overview 38
10.2	Boot Order 40
10.3	NICs 40
10.4	NIC and LOM Enumeration 40
10.5	PCI Card Dimensions 40
11	Storage 41
11.1	Overview 41
11.2	RAID Configurations 41
11.3	LED Indicators 43
11.4	Optical Drives 43
11.5	Tape Drives 43
11.6	External Storage 43
12	Video 44
13	Rack Information 45
13.1	Overview 45
13.2	Rails 45
13.2.1	Sliding Rails 45
13.2.2	Static Rails 46
13.3	Cable Management Arm (CMA) 48
14	Operating Systems and Virtualization 49
15	Systems Management 50
15.1	Overview/Description 50
15.2	Server Management 50

Dell

15.3 Embedded Server Management.....	50
15.4 Lifecycle Controller and Unified Server Configurator	51
15.5 iDRAC Express	51
15.6 iDRAC6 Enterprise	52
16 USB Peripherals	54
Appendix A. Statement of Volatility	55
Appendix B. Certifications.....	59
B.1 Regulatory Certifications.....	59
B.2 Product Safety Certifications	59
B.3 Electromagnetic Compatibility	60
B.4 Ergonomics, Acoustics and Hygienics	60
Appendix C. Additional Information and Options.....	61

Tables

Table 1. Feature Comparison to SC1435, R410, and R610.....	8
Table 2. Product Features Summary	11
Table 3. Power Supply Status.....	16
Table 4. Power Supply Specifications	23
Table 5. Heat Dissipation	24
Table 6. Environmental Specifications.....	24
Table 7. Acoustical Performance	26
Table 8. Supported Processor Description and Features	27
Table 9. DIMMS Supported	29
Table 10. Supported Configurations (1 Processor)	30
Table 11. Supported Configurations (2 Processors).....	31
Table 12. BIOS Power Management Features	34
Table 13. BIOS Power Management Profiles	35
Table 14. Supported Expansion Cards	38
Table 15. Supported Hard Drives	41
Table 16. RAID Configurations	41
Table 17. Graphics Video Modes.....	44
Table 18. Supported Racks	47
Table 19. Rail Adjustability Ranges and Depth	48
Table 20. Unified Server Configurator Features and Description	51
Table 21. Features List for BMC, iDRAC, and vFlash.....	52
Table 22. R415 Volatility Table.....	55
Table 23. Product Safety Certifications	59
Table 24. Electromagnetic Compatibility Certifications	60
Table 25. Ergonomics, Acoustics and Hygienics	60
Table 26. Industry Standards.....	61

Figures

Figure 1. R415 Chassis Dimensions.....	14
Figure 2. Front View (Cabled HDD with LED).....	15
Figure 3. Front View (Hot-Plug HDD with LCD)	15
Figure 4. Front View (With Optional Bezel)	15
Figure 5. Back View (Non-Redundant Power Supply)	15
Figure 6. Back View (Redundant Power Supply)	16
Figure 7. Left Side View.....	16

Dell

Figure 8. Right Side View 16

Figure 9. Internal Chassis View 17

Figure 10. R415 Mounted in A3 Sliding Rails 18

Figure 11. Back View of R415 Mounted in A3 Sliding Rails with CMA 18

Figure 12. R415 Mounted in A4 Static Rails (2-Post Center Mount Configuration)..... 19

Figure 13. PowerEdge R415 Fans 19

Figure 14. LED panel Configuration 20

Figure 15. LED Panel (Detailed View)..... 20

Figure 16. LCD Panel Configuration 20

Figure 17. LCD Panel (Detailed View)..... 20

Figure 18. R415 Sliding Rails with Optional CMA 45

Figure 19. 1U Threaded Rack Adapter Brackets Kit..... 46

Figure 20. R415 Static Rails 47

1 Product Comparison

1.1 Overview

The Dell™ PowerEdge™ R415 is a 2-socket 1U rack server that is designed to deliver outstanding value. The R415 is built with the latest AMD Opteron™ series processors for remarkable price for performance, and it features hot-swap hard drives and redundant power supplies to provide availability options for better business data protection.

The R415 packs other enterprise-class features, such as advanced systems management capabilities and an optional interactive LCD screen for easy system monitoring. These features help meet the needs of many small to mid-sized businesses as well as address many data center demands with superior stability, efficiency and long-term business value.

1.1.1 Designed to Go the Distance

You've told us you need a server manufacturer that inspires confidence through its reliability, availability, and quality of products. That is why we have designed the PowerEdge R415 for optimal reliability and ease of use, incorporating customer-inspired features that range from robust metal hard-drive carriers and industrial-quality materials to embedded diagnostics and an optional interactive LCD screen.

Our reliability goals are simple: Deliver quality products that stand the test of time.

- A Unified Server Configurator (USC) helps minimize downtime by offering embedded and persistent diagnostics with no media requirements.
- A one-touch quality-control process enables single-person responsibility for an entire server build.
- Every Dell server model is tested and re-tested before it leaves the factory.
- Our operating system, application and software integration testing, and validation help ensure that everything works together right out of the box.
- A focus on product longevity provides longer, fully supported product lifecycles for better investment protection.

1.1.2 Efficient from the Inside Out

The PowerEdge R415 was designed to provide you with a multitude of time- and energy-saving options, not only inside the server, but outside as well.

Inside the server, we have Energy Smart technologies to help you better manage power. This includes low-wattage processors, support for low-voltage DIMMs, and efficient fans that spin in accordance with server workload demands. Internal shrouding and logical component layouts aid with airflow direction, helping to cool the server. Energy-efficient power supplies use power effectively without compromising business productivity.

Outside the server, we have put the external ports, power supplies, and LED lights or LCD screens in the same locations as other 11th generation PowerEdge servers for a familiar server-to-server usability and commonality, as well as for easy installation and deployment. The hard drives across the 11G servers are also interchangeable, since they share the same drive carriers.

1.1.3 Easy to Manage

As an IT professional, you do not have a lot of time to spend managing and maintaining your systems. That is why the Dell systems-management portfolio focuses on two core principles to make your life easier: simplicity and cost-effectiveness.

The optional Lifecycle Controller helps you perform system diagnostics, hardware configuration, and system deployment in a pre-operating-system environment from an easy-to-use interface called the Unified Server Configurator (USC). This helps eliminate the need to use and maintain multiple pieces of CD/DVD media, and helps get your server up and running fast.

An optional interactive LCD screen on the front of the server allows for easy setup, monitoring, and maintenance. Plain-language diagnosis and a programmable messaging system can help you address issues quickly to simplify day-to-day monitoring.

The Dell Management Console, which is included with every Dell server, provides you with a consolidated console view of your IT infrastructure.

Automated update notification from Support.Dell.com provides you with the latest updates for firmware, drivers and BIOS so your systems are always running at their best.

1.2 Comparison

Table 1. Feature Comparison to SC1435, R410, and R610

Feature	SC1435 (predecessor)	R410	R415	R610
Processor	AMD Opteron™ 2000 series	Intel® Xeon® processor 5500 and 5600 series	AMD Opteron™ 4100 series	Intel® Xeon® processor 5500 and 5600 series
Form Factor	1U rack	1U rack	1U rack	1U rack
# Sockets	1 or 2	1 or 2	1 or 2	1 or 2
# Cores	2 or 4	2 or 4	4 or 6	2 or 4
Front Side Bus	HyperTransport 1GBz	Intel® QuickPath Interconnect (QPI) 6.4GT/s	HyperTransport 3 (HT3) 5.2GT/s	Intel® QuickPath Interconnect (QPI) 6.4GT/s
L2/L3 Cache	1.5MB per core/6MB	Up to 12MB	512KB per core/6MB	Up to 12MB
Chipset	Broadcom® HT-2100, HT-1000	Intel® 5500	AMD SR 5670	Intel® 5520
DIMMs	8 DDR2 RDIMM 667MHz	4+4 DDR3 UDIMM or RDIMM 1333/1066/800MHz	8 x DDR3 UDIMM, RDIMM, or LV RDIMM 1333/1066/800/667MHz	6+6 DDR3 UDIMM or RDIMM 1333/1066/800MHz
Min/Max RAM	512MB/32GB	1GB/128GB	1GB/128GB ¹	1GB/192GB
HD Bays	2 x 3.5"	4 x 3.5" or 4 x 2.5" Optional hot-plug Supports 2.5" drives with HDD carrier	4 x 3.5" or 4 x 2.5" Optional hot-plug Supports 2.5" drives with HDD carrier	6 x 2.5" hot-plug
HD Types	SATA, SAS	SATA, SAS, SSD	SATA, SAS, SSD	SAS, SSD
Ext Drive Bay(s)	1 for slim optical drive	1 for slim optical drive	1 for slim optical drive	1 for slim optical drive

Feature	SC1435 (predecessor)	R410	R415	R610
Embedded HD Controller	Chipset-based SATA	Chipset-based SATA	Chipset -based SATA	SAS 6/iR
Optional Storage Controller	RAID: SAS 5/iR SAS 6/iR	Non-RAID: SAS 5/E LSI 2032 (for tape backup unit only) RAID: SAS 6/iR Modular PERC 6/i PERC 6/E PERC H200 PERC H700 PERC H800	Non-RAID: LSI 2032 (for tape backup unit only) RAID: SAS 6/iR Modular PERC S300 PERC H200 PERC H700 PERC H800	Non-RAID: SAS 5/E LSI 2032 (for tape backup unit only) RAID: SAS 6/iR PERC 6/i PERC 6/E PERC H200 PERC H700 PERC H800
Availability	Toolless chassis, quad-pack LED for diagnostic	Hot-plug hard drives, redundant power supplies, quad-pack LED diagnostic or LCD (with hot-plug hard drive chassis), memory mirroring	Hot-plug hard drives, redundant power supplies, quad-pack LED diagnostic or LCD (with hot-plug hard drive chassis), memory mirroring	Hot-plug hard drives, redundant power supplies, LCD diagnostic, memory mirroring or sparing, internal SD card for embedded Hypervisor
Server Management	BMC, IPMI 2.0 compliant, Dell Server Assistant	BMC, IPMI 2.0 compliant, full Dell OpenManage™ suite; Optional: iDRAC6 Express, iDRAC6 Enterprise, vFlash	BMC, IPMI 2.0 compliant, full Dell OpenManage™ suite; Optional: iDRAC6 Express, iDRAC6 Enterprise, vFlash	iDRAC6 Express, BMC, IPMI 2.0 compliant, full Dell OpenManage™ suite; Optional: iDRAC6 Enterprise, vFlash
I/O Slots	1 PCIe x8 or one PCI-X 64/133; full height, half length	1 x PCIe x16 (true x16, Gen2); full height, half length	1 x PCIe x16 (true x16, Gen2); full height, half length	2 x PCIe x8; full height, half length
NIC/LOM	2 x GbE LOMs Optional: various NICs available	2 x GbE LOMs Optional: various NICs available	2 x GbE LOMs Optional: various NICs available	2 x GbE LOMs w/ TOE Optional: various NICs available
USB	2 front, 2 rear	2 front, 2 rear, 2 internal	2 front, 2 rear, 2 internal	2 front, 2 rear, 1 internal
Hypervisor (with internal SD card)	No	No	No	Yes

Feature	SC1435 (predecessor)	R410	R415	R610
Power Supplies	Non-redundant 600W Auto Ranging (90V-264V)	Non-redundant 480W (80+ SILVER) Optional redundant 500W (80+ GOLD) Auto Ranging (100V-240V)	Non-redundant 480W (80+ SILVER) Optional redundant 500W (80+ GOLD) Auto Ranging (100V-240V)	Redundant 502W (high efficiency) Redundant 717W (high capacity)
Fans	Non-redundant, non-hot-pluggable	Non-redundant, non-hot-pluggable	Non-redundant, non-hot-pluggable	Redundant, hot- pluggable
Dimensions (HxWxD)	42.6 x 426.2 x 609.6 (mm) 1.68 x 16.78 x 24 (in)	43.0 x 434.0 x 627.1 (mm) (without ear, without bezel) 1.69 x 17.09 x 24.69 (in)	43.0 x 434.0 x 627.1 (mm) (without ear, without bezel) 1.69 x 17.09 x 24.69 (in)	42.6 x 482.4 x 772 (mm) (with latches, bezel, and power supply handles) 1.68 x 18.99 x 30.39 (in)
Weight	Max: 14.1Kg (31.0lbs)	Max: 15.9Kg (35.02lbs)	Max: 15.9Kg (35.02lbs)	Max: 17.69Kg (39lbs)

¹ 128 GB maximum memory will be available using 16 GB DIMMs (available Q1 2011).

2 System Overview

Table 2 provides an overview of the PowerEdge R415 server features.

Table 2. Product Features Summary

Feature	Technical Specification	
Form Factor	1U rack	
Processors	AMD Opteron™ 4100 series processors	
Processor Sockets	2	
Front Side Bus or HyperTransport	HyperTransport-3 Links	
Cache	L2: 512K/core L3: 6MB	
Chipset	AMD (SR5670 and SP5100)	
Memory ¹	Up to 128GB ² (8 DIMM slots) 1GB/2GB/4GB/8GB/16GB ² 1333MHz	
I/O Slots	1 x PCIe G2 slot: Slot 1: PCIe x16 Slot 2: Proprietary for embedded SAS 6/iR or PERC S300 modular card only	
RAID Controller	Internal Controllers: PERC H200 (6Gb/s) PERC H700 (6Gb/s) (non-volatile battery-backed cache: 512MB, 1G) SAS 6/iR PERC S300 (software-based)	External Controllers: PERC H800 (6Gb/s) (non-volatile battery-backed cache: 512MB, 1G) External HBA (non-RAID): 6GB/s SAS HBA
Drive Bays	Up to four 2.5" or 3.5" SAS, SATA, or SSD hard drives (cabled or optional hot-plug)	
Maximum Internal Storage	8TB	
Hard Drives ¹	3.5" SATA (7.2K rpm): 160GB, 250GB, 500GB, 1TB, 2TB 3.5" Nearline SAS (7.2K rpm): 500GB, 1TB, 2TB 3.5" SAS (15K rpm): 146GB, 300GB, 450GB, 600GB	2.5" SAS (10K rpm): 146GB, 300GB, 600GB 2.5" Nearline SAS (7.2K rpm): 1TB 2.5" SATA SSD: 50GB, 100GB

Feature	Technical Specification	
Communications	<p>Optional add-in NICs:</p> <p>Intel® 10GBase-T Copper Single Port NIC, PCIe x8</p> <p>Intel® PRO 1000 PT Single Port Adapter, Gigabit Ethernet NIC, PCIe x1</p> <p>Intel® Gigabit ET Dual Port Server Adapter, PCIe x4</p> <p>Intel® Gigabit ET Quad Port Server Adapter, PCIe x4</p> <p>Intel® Ethernet X520 DA2 Dual-Port 10 Gigabit Server Adapter</p> <p>Intel® X520-T2 Dual-Port 10 Gigabit Ethernet Server Adapter</p> <p>Broadcom® BCM5709C IPV6 Gigabit Copper Dual Port with TOE and iSCSI Offload, PCIe x4</p> <p>Broadcom® BCM5709C IPV6 Gigabit Copper Dual Port NIC with TOE, PCIe x4</p> <p>Broadcom® BCM5709C 10/100/1000BASET Quad Port NIC</p> <p>Broadcom® NetXtreme™ II 57711 Dual-Port SFP+/Direct Attach 10Gb Ethernet PCIe with TOE and iSCSI Offload</p>	<p>Optional add-in HBAs:</p> <p>Brocade® 1020 10G Converged Network Adapter (CNA)-dual port</p> <p>Emulex® LPe11002 FC4 HBA, Dual Port</p> <p>Emulex® LPe1150 FC4 HBA, Single Port</p> <p>Emulex® LPe12000 8Gbps FC HBA, Single Port</p> <p>Emulex® LPe12002 8Gbps FC HBA, Dual Port</p> <p>Emulex® OCE10102FXD, 10G PCI-e FCoE CNA, Dual Port</p> <p>Qlogic® QLE220 FC4 HBA, Single Port</p> <p>Qlogic® QLE2460 FC4 HBA, Single Port</p> <p>Qlogic® QLE2462 FC4 HBA, Dual Port</p> <p>Qlogic® QLE2560 8Gbps FC HBA, Single Port</p> <p>Qlogic® QLE2562 8Gbps FC HBA, Dual Port</p> <p>Qlogic® QLE8152 8Gbps FC HBA, Dual Port</p> <p>Brocade® FC HBA BR815</p> <p>Brocade® FC HBA BR825</p>
Power Supply	Non-redundant 480W (80+ BRONZE) or Optional redundant 500W (80+ SILVER)	
Availability	Hot-plug hard drives, hot-plug redundant power, ECC memory, quad-pack LED diagnostic (interactive LCD only with hot-plug HDD chassis)	
Video	Matrox® G200eW with 8MB memory	
Remote Management	Optional: iDRAC6 Express, iDRAC6 Enterprise, and vFlash	
Systems Management	<p>Dell OpenManage™ featuring Dell Management Console</p> <p>BMC, IPMI 2.0 compliant</p> <p>Lifecycle Controller enabled with optional iDRAC6 Express or iDRAC6 Enterprise and vFlash</p> <p>Unified Server Configurator</p>	
Rack Support	<p>ReadyRails™ sliding rails for 4-post racks with support for optional cable management arm, or</p> <p>ReadyRails™ static rails for 4-post and 2-post racks</p>	

Feature	Technical Specification
Operating Systems	Microsoft® Windows® Small Business Server 2008 Microsoft® Windows Server® 2008 SP2, x86/x64 (x64 includes Hyper-V™) Microsoft® Windows Server® 2008 SP2 R2, x64 (includes Hyper-V™ v2) Microsoft® Windows® HPC Server 2008 Novell® SUSE® Linux® Enterprise Server Red Hat® Enterprise Linux® Optional Embedded Hypervisors: Citrix® XenServer® VMware® vSphere™ 4.1 (including VMware ESX® 4.1 or VMware ESXi™ 4.1) For more information on the specific versions and additions, visit www.dell.com/OSsupport .
Featured Database Application	Microsoft® SQL Server® solutions (see Dell.com/SQL)
<p>¹GB means 1 billion bytes and TB equals 1 trillion bytes; actual capacity varies with preloaded material and operating environment and will be less.</p> <p>²128 GB maximum memory will be available using 16 GB DIMMs (available Q1 2011).</p>	

3 Mechanical

3.1 Chassis Description

The PowerEdge R415 chassis was designed to deliver a value-based, high-performance server that also offers a level of redundancy. The PowerEdge R415 is available in two chassis configurations:

- Cabled hard drive chassis with LED module
- Hot-plug hard drive chassis with LCD module

Common features for the two available chassis include the following:

- Four 2.5” or 3.5” SATA or SAS hard drives (cabled or hot-plug)
- 2.5” SSD hard drives
- Power supply (non-redundant or redundant)
- Dual gigabit LOMs without TOE acceleration
- Four DIMM slots supporting each processor
- Trusted Platform Module (TPM); in China, the S-TPM (Socket TPM) is used
- Riser card for optional PCIe expansion card
- Optional iDRAC6 Enterprise and iDRAC6 Express card (mounted on planar without PCI slot occupied)
- Support for 11G slim static and slim sliding rails

3.2 Dimensions and Weight

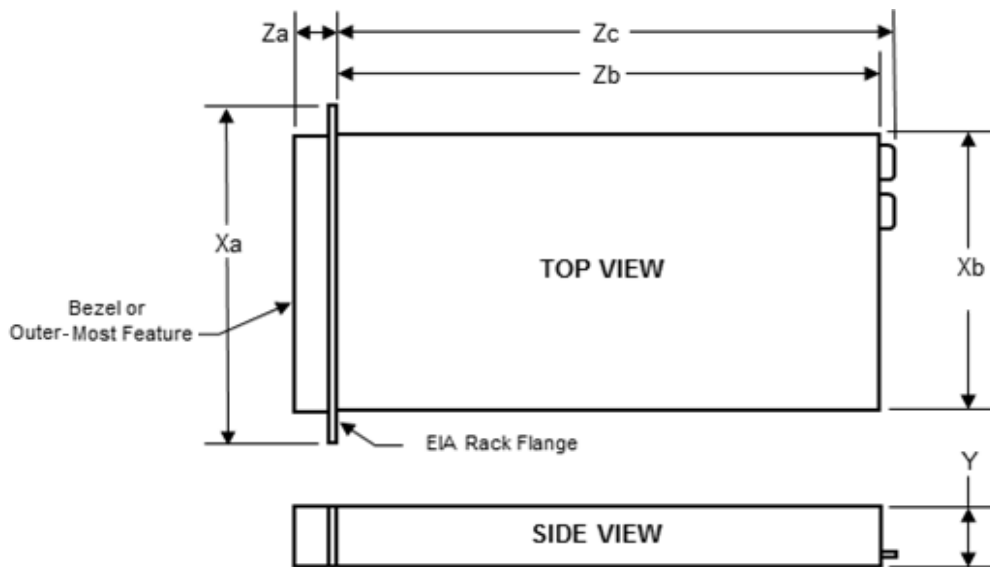

Xa	Xb	Y	Za w/ bezel	Za w/o bezel	Zb*	Zc	Max Weight
482.4mm	434.0mm	43.0mm	35.0mm	20.1mm	606.0mm	641.9mm	15.9Kg

Figure 1. R415 Chassis Dimensions

*Zb measures to the nominal back wall external surface where the motherboard I/O connectors reside.

3.3 Front Panel View and Features

The PowerEdge R415 is available in two chassis configurations: cabled hard drive and hot-plug hard drive. The cabled hard drive chassis includes an LED control panel (Figure 2), and the hot-plug hard drive chassis includes an LCD control panel (Figure 3). The bezel is optional for both system configurations. See Figure 4.



Figure 2. Front View (Cabled HDD with LED)



Figure 3. Front View (Hot-Plug HDD with LCD)



Figure 4. Front View (With Optional Bezel)

See the Front-Panel Features and Indicators section in the About Your System chapter of the *PowerEdge R415 Hardware Owner's Manual* on Support.Dell.com for more information.

3.4 Back Panel View and Features

The PowerEdge R415 is available with two power-supply configurations: non-redundant and redundant. See Figure 5 (non-redundant power supply) and Figure 6 (redundant power supply).



Figure 5. Back View (Non-Redundant Power Supply)







Figure 6. Back View (Redundant Power Supply)

See the Back-Panel Features and Indicators section in the About Your System chapter of the *PowerEdge R415 Hardware Owner's Manual* on Support.Dell.com for more information.

3.5 Power Supply Indicators

The PowerEdge R415 power supplies (redundant and non-redundant) have one status bi-color LED: green for AC power present and amber for a fault.

Table 3. Power Supply Status

LED	Power Supply Status
	AC Power is not present
	AC Power is present
	Fault of any kind is detected
	DC Power is applied to the system
	Redundant power supply mismatch (when hot-plugged/swapped)

See the Power Indicator Codes section in the About Your System chapter of the *PowerEdge R415 Hardware Owner's Manual* on Support.Dell.com for more information.

3.6 NIC Indicators

See the NIC Indicator Codes section in the About Your System chapter of the *PowerEdge R415 Hardware Owner's Manual* on Support.Dell.com for more information.

3.7 Side Views

Side views of the PowerEdge R415 are shown in Figure 7 and Figure 8.



Figure 7. Left Side View



Figure 8. Right Side View

3.8 Internal Chassis View

Figure 9 shows the internal chassis view.

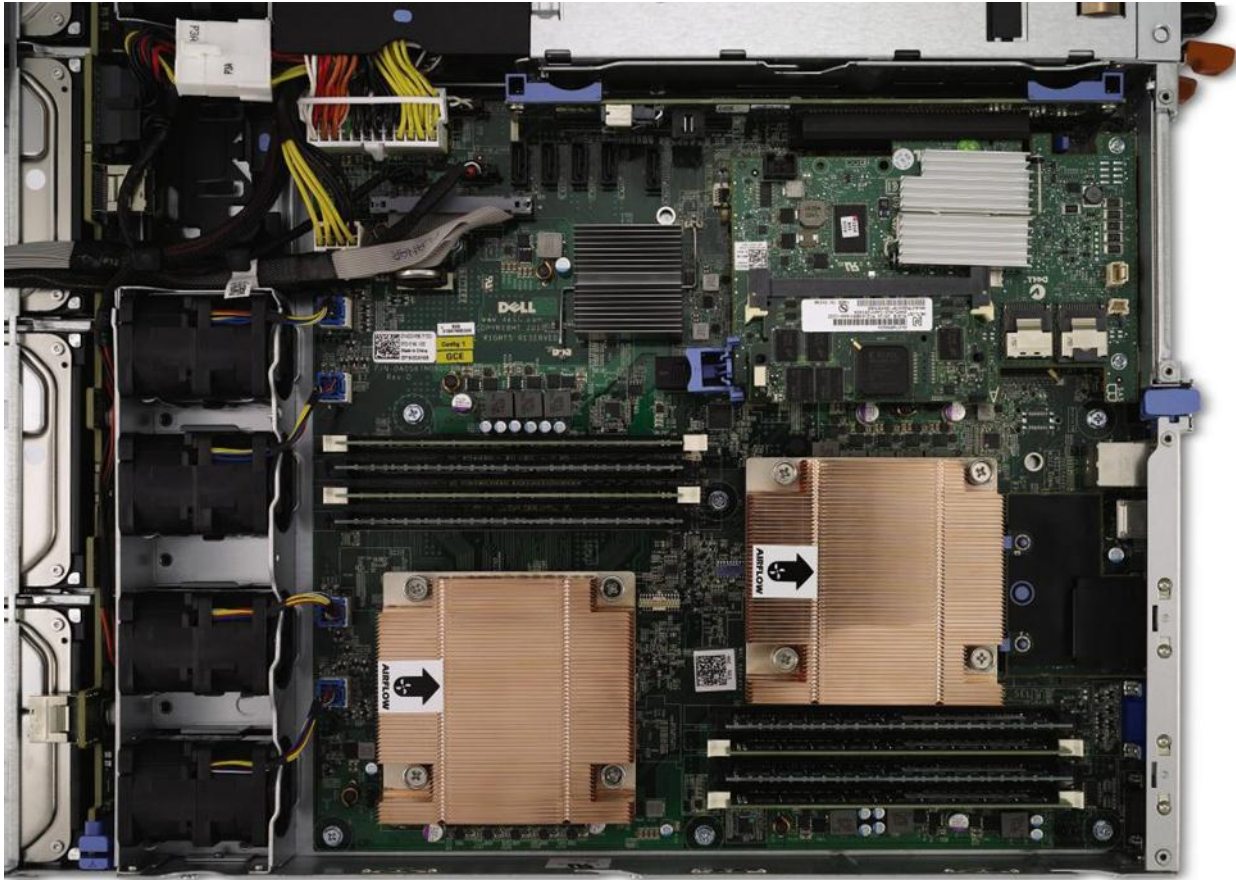

Figure 9. Internal Chassis View

3.9 Rails and Cable Management

3.9.1 ReadyRails Sliding Rails

ReadyRails™ Sliding Rails for 4-post racks include the following support:

- Toolless installation in 19" EIA-310-E compliant square or unthreaded round hole 4-post racks, including all generations of Dell racks
- Toolled installation in 19" EIA-310-E compliant threaded hole 4-post racks (requires the 1U Threaded Rack Adapter Brackets Kit)
- Full extension of the system out of the rack to allow serviceability of key internal components
- Optional cable management arm (CMA)

3.9.2 ReadyRails Static Rails

ReadyRails™ Static Rails for 4-post and 2-post racks include the following support:

- Toolless installation in 19" EIA-310-E compliant square or unthreaded round hole 4-post racks including all generations of Dell racks
- Toolled installation in 19" EIA-310-E compliant threaded hole 4-post and 2-post racks

For more information on rails, see section 13.2.

3.10 Rack View

3.10.1 Sliding Rails

See Figure 10 and Figure 11 for views of the PowerEdge R415 mounted in A3 sliding rails.



Figure 10. R415 Mounted in A3 Sliding Rails



Figure 11. Back View of R415 Mounted in A3 Sliding Rails with CMA

3.10.2 Static Rails

The R415 static rails are a stab-in design, but unlike the sliding rails, they do not include middle (intermediate) rail members. After the inner (chassis) rail members have been attached to the sides of the chassis, they are inserted directly into the outer (cabinet) rail members installed in the rack. See Figure 12 for a view of the R415 mounted in A4 static rails.



Figure 12. R415 Mounted in A4 Static Rails (2-Post Center Mount Configuration)

3.11 Fans

There are total of six fans with redundant power supplies in the system and four fans with non-redundant power supplies.

Figure 13 shows the PowerEdge R415 fans. The four fans at right are the fans for the system, specifically for the processors and memory modules. The two fans at left are present when the system is configured with redundant power supplies, for which they provide cooling.

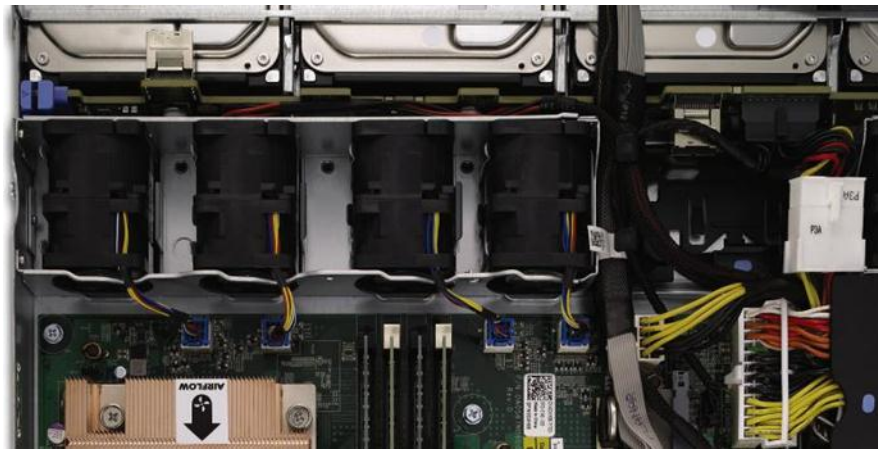

Figure 13. PowerEdge R415 Fans

3.12 Control Panel

The PowerEdge R415 is available in an LED panel configuration and an optional LCD panel configuration.

3.12.1 LED Panel Configuration

Figure 14 and Figure 15 show the LED panel.



Figure 14. LED panel Configuration



Figure 15. LED Panel (Detailed View)

For a complete description of LED indicators, their causes, and possible courses of action to take to resolve an error, see the Diagnostic Lights (Optional) section in the About Your System chapter in the *PowerEdge R415 Hardware Owner's Manual* on Support.Dell.com.

3.12.2 LCD Panel Configuration

Figure 16 and Figure 17 show the LCD panel.



Figure 16. LCD Panel Configuration



Figure 17. LCD Panel (Detailed View)

The LCD panel is located on the front of the system chassis to provide user access to buttons, display, and I/O interfaces. Features of the LCD panel include the following:

- ACPI-compliant power button with an integrated green power LED (controlled by iDRAC6)
- 128x20 pixel LCD screen with controls
- Two navigation buttons
- Select button
- System ID button
- Non-maskable Interrupt (NMI) button (recessed)
- Ambient temperature sensor

Dell

The LCD panel is a graphics display controlled by iDRAC6. Error codes can be sent to the display by either iDRAC6 or BIOS.

The system's LCD panel provides system information and status messages to signify when the system is operating correctly or when the system needs attention.

BIOS has the ability to enter a secure mode through Setup, which locks the Power and NMI buttons. When in this mode, the power button can still be used to turn on the system, but it cannot be used to turn off power to the system.

For more information on the LCD panel, see the LCD Panel Features (Optional) section in the About Your System chapter in the *PowerEdge R415 Hardware Owner's Manual* on Support.Dell.com.

3.13 Security

For additional information regarding the PowerEdge R415 security features listed below, see the *PowerEdge R415 Hardware Owner's Manual* on Support.Dell.com.

3.13.1 Cover Latch

The PowerEdge R415 comes with a coin-lock entry latch on the top cover of the unit and provides security for the entire system. The lock provides for toolless access to the chassis.

3.13.2 Bezel

A metal bezel is an available option and is mounted to the chassis front to provide the Dell ID. A lock on the bezel prevents unauthorized access to system peripherals and the control panel. System status remains viewable when the bezel is installed.

3.13.3 Hard Drive

Hot-plug hard drives are only accessible by opening the bezel, thus locking the bezel secures the hard drives. Cabled hard drives are only accessible by opening the top cover, thus locking the top cover will secure the hard drives.

3.13.4 Trusted Platform Module (TPM)

The TPM is used to generate/store keys, protect/authenticate passwords, and create/store digital certificates. TPM can also be used to store the Microsoft® BitLocker™ keys for hard drive encryption features in Microsoft® Windows Server® 2008. TPM is enabled through a BIOS option and uses HMAC-SHA1-160 for binding. In China, the S-TPM (Socket TPM) is used.

3.13.5 Power Off Security

The control panel is designed such that the power switch cannot be accidentally activated. The lock on the bezel secures the power button behind the bezel. In addition, there is a setting in the CMOS setup that disables the power button function.

3.13.6 Intrusion Alert

A chassis intrusion switch is located at the front panel board. The switch detects when the top cover is opened.

3.13.7 Secure Mode

BIOS can enter a secure boot mode through setup. This mode includes the option to lock out the power and NMI switches on the control panel or to set up a system password.

3.14 USB Key

Dell does not offer USB keys for factory installation. The PowerEdge R415 supports two internal USB connectors which can be used for USB keys.

3.15 Battery

A replaceable coin-cell CR2032 3V battery is mounted on the planar to provide backup power for the Real-Time Clock and CMOS RAM on the AMD SP5100 chip.

3.16 Field Replaceable Units (FRU)

Parts available for field replacement include:

- Backplane
- CMOS battery
- Expansion card
- Front bezel
- Hard drives
- I/O panel
- Memory
- Optical disk drive
- Power distribution board
- Power supply
- Processor
- Processor shroud
- System board
- System cover
- System fan

For detailed information on replacing parts for the PowerEdge R415, see the Installing System Components chapter in the *PowerEdge R415 Hardware Owner's Manual* on Support.Dell.com.

3.17 User Accessible Jumpers, Sockets, and Connectors

See the Jumpers and Connectors chapter in the *PowerEdge R415 Hardware Owner's Manual* on Support.Dell.com.

4 Power, Thermal, Acoustic

4.1 Power Supplies

The PowerEdge R415 is powered by either a non-redundant 480W power supply or an optional redundant 500W power supply.

The power supply subsystem provides power to the planar, the four internal hard drive bays, and one slim optical disk drive bay. Power is soft-switched, allowing power cycling using a switch on the front of the system enclosure or through software control (through server management functions). The power system is compatible with industry standards, such as ACPI and Server 2000.

For a redundant power supply configuration, the second power supply provides hot-pluggable power redundancy. In redundant mode, the system distributes the power load across both power supplies to maximize efficiency. When a power supply is removed with the system powered on, the full power load is picked up by the remaining power supply.

If using only one hot-plug power supply, the power supply is installed in the PS1 location and a blank module (metal cover) is installed in the PS2 location for factory consistency. Electrically, the system can operate with a single power supply in either bay. The power supply has automatic input voltage detection. An auxiliary power-out receptacle is not provided on this unit.



The power supply in the chassis has been rated as 82% efficient at 20% and 100% loads, and 85% efficient at a 50% load under 115V AC input line. Redundant power efficiency is 88% at 20% and 100% loads, and 92% efficiency at a 50% load under 230V AC input line.

Field replaceable unit (FRU) data is stored in the memory of the power supply microcontroller. Additionally, the power supply firmware can be updated by the baseboard management controller (BMC) over the PMBus.

4.2 Power Supply Specifications

Table 4 shows the power supply specifications.

Table 4. Power Supply Specifications

Feature	Non-Redundant Power Supply	Redundant Power Supply
Dimensions	L-260 ¹ x W-106 x H-40.0 (mm)	L-260 ¹ x W-54.5 x H-38.0 (mm)
Status Indicators	1 x bi-color LED	1 x bi-color LED
Integrated Fans	None	None
Fixed Input Plug	IEC-C14 	IEC-C14 
AC Cord Rating	15A @ 120VAC, 10A @ 240VAC	15A @ 120VAC, 10A @ 240VAC
Input Voltage	90-264VAC	90-264VAC
Auto-ranging	Yes	Yes
Line Frequency	47-63Hz	47-63Hz
Maximum Inrush Current	Under typical line conditions and over the entire system	Under typical line conditions and over the entire system

Feature	Non-Redundant Power Supply	Redundant Power Supply
	ambient operating range, the inrush current may reach 25A per power supply for 10ms or less.	ambient operating range, the inrush current may reach 25A per power supply for 10ms or less.
Hot-plug Capability	No	Yes
Output Power	480W	500W
Efficiency 20% to 100% Load	82-85% @115VAC 82-85% @ 230VAC	86-90% @115VAC 88-92% @ 230VAC
Energy Star Certification & Compliance	80+ Bronze	80+ Silver

[†] Does not include the power supply handle or ejection tab.

4.3 Heat Dissipation

Table 5 details heat dissipation for the PowerEdge R415.

Table 5. Heat Dissipation

Description	Non Redundant Power Supply	Redundant Power Supply
Wattage	480W	500W
Voltage	100-240VAC, 50-60Hz, 7.5-3.8	100-240VAC, 50-60Hz, 7.5-3.8
Heat Dissipation	1637 BTU/hr maximum	1706 BTU/hr maximum

4.4 Environmental Specifications

Table 6 summarizes the environmental specifications for the PowerEdge R415.

Table 6. Environmental Specifications

Temperature	
Operating	10° to 35° C (50° to 95° F) with a maximum temperature gradation of 10° C per hour Note: For altitudes above 2950 feet, the maximum operating temperature is derated 1° F/550 ft.
Storage	-40° to 65° C (-40° to 149° F) with a maximum temperature gradation of 20° C per hour
Relative Humidity	
Operating	20% to 80% (noncondensing) with a maximum humidity gradation of 10% per hour
Storage	5% to 95% (noncondensing) with a maximum humidity gradation of 10% per hour

Maximum Vibration	
Operating	0.26Grms at 5-350Hz in operational orientations
Storage	1.87Grms at 10-500Hz in all orientations
Maximum Shock	
Operating	Half sine shock in all operational orientations of 31G +/- 5% with a pulse duration of 2.6ms +/-10%
Storage	Half sine shock on all six sides of 71G +/- 5% with a pulse duration of 2ms +/-10% Square wave shock on all six sides of 27G with velocity change @ 235 in/sec or greater
Altitude	
Operating	-16 to 3048m (-50 to 10,000ft) Note: For altitudes above 2950 feet, the maximum operating temperature is derated 1° F/550ft.
Storage	-16 to 10,600m (-50 to 35,000ft)

The airborne contaminant level is class G2 or lower as defined by ISA-S71.04-1985.

4.5 ENERGY STAR® Compliance

ENERGY STAR qualified configurations can be accessed from the [ENERGY STAR Compliance results](#) landing page on Dell.com.

4.6 Thermal

The thermal design of the PowerEdge R415 includes the following:

- Closed loop thermal control algorithm: This method uses feedback temperatures to dynamically determine proper fan speeds.
- Comprehensive thermal management: The PowerEdge R415 controls system cooling fan speed based on several different responses from critical component sensors, such as processor temperature, DIMM temperature, inlet ambient temperature, and system configurations. The thermal management adjusts proper cooling ability for the system according to what the system really needs.
- Optimized Ventilation: The R415 chassis has a custom ventilation design for optimized air flow path. Each component and peripheral is ensured sufficient air for cooling.
- Power-to-Cool: Dell continues to improve the designs and cooling efficiency for server products.

4.7 Acoustics

The acoustical design of the PowerEdge R415 reflects adherence to Dell's high sound-quality standards. Sound quality is different from sound power level and sound pressure level in that it describes how humans respond to annoyances in sound, like whistles, hums, etc. One of the sound quality metrics in the Dell specification is prominence ratio of a tone as shown in Table 7.

Fan speeds and noise levels ramp up during the boot process to add a layer of protection for component cooling if the system were not to boot properly. Hardware configurations affect system noise levels. The table below shows the noise levels of the R415 with different configurations.

Table 7. Acoustical Performance

Configuration @ 23 ± 2 °C				Operating Mode	L _{WA} -UL (Bels)	L _{pA} (dBA)	Prominent Tones
CPU	RAID	DIMM	Power Supply				
1 x AMD 4122 4 core 2.2GHz	Embedded SAS 6/iR	1 x 1GB	1 x 480W Non-redundant	Idle	5.5	39	None
				Stressed	5.5	39	None
2 x AMD 4122 4 core 2.2GHz	Embedded SAS 6/iR	4 x 2GB	2 x 500W Redundant	Idle	5.6	40	None
				Stressed	5.6	40	None
2 x AMD 4184 6 core 2.8GHz	PERC H800	8 x 8GB	2 x 500W Redundant	Idle	5.9	46	None
				Stressed	6.4	46	None

Definitions

Idle: Reference ISO7779 (1999) definition 3.1.7; system is running in its OS but no other specific activity.

Stressed Processor: An operating mode per ISO7779 (1999) definition 3.1.6. The software SPECPower_ssj2008 is utilized to stress the processors. SPECPower is set to 50% loading.

L_{WA} - UL: The upper limit sound power level (L_{WA}) calculated per section 4.4.2 of ISO 9296 (1988) and measured in accordance to ISO 7779 (1999).

L_{pA}: Average bystander A-weighted sound pressure level. The system is placed in a rack with its bottom at 25 cm from the floor. The acoustic transducers are at the four bystander positions, ref ISO7779 (1999) Section 8.6.2.

Prominent tone: Criteria of D.5 and D.8 of ECMA-74 9th ed. (2005) are followed to determine if discrete tones are prominent. The system is placed in a rack with its bottom at 75 cm from the floor. The acoustic transducer is at front bystander position, ref ISO7779 (1999) Section 8.6.2.

5 Processors

5.1 Overview

The PowerEdge R415 utilizes the latest four- and six-core offerings from the AMD Opteron™ 4000 series (C32).

5.2 Features

Key features of the C32 processor include the following:

- Performance for blades and cost-effective DP servers
 - Up to six cores per processor
 - Up to 6M L3 Cache for 6-core processors (512 KB per core L2)
 - Enhanced AMD power efficiency features:
 - CoolCore™ Technology,
 - Enhanced AMD PowerNow!™
 - APML
 - Demand-based switching for active processor power management, as well as support for ACPI P-States and C-States
 - C1E support
 - AMD CoolSpeed
 - Dual-channel U/RDDR3 up to 1333 MHz, ECC
 - Up to 3 DIMMs per channel, 6 per processor (R415 supports up to 2 DIMMs per channel, 4 per processor)
 - Low voltage (LV) DIMM support (6-core processor only)
 - Designed for thermally-constrained environments
 - 45 nm process technology
 - PCIe Gen 2 with up to 42 lanes with 9 controllers (SR5670)
 - Single series for UP and DP platforms (enterprise scalability and features for 1P)
- New C32 socket infrastructure
 - Lower power/thermal bands
 - Dual 16-bit HT3 links, up to 6.4 GT/s per link
 - Workload-optimized platforms (SR5670 chipset for expandable SMB)

5.3 Supported Processors

Table 8. Supported Processor Description and Features

Model	Speed	Power	Cores	L2/L3 Cache	HyperTransport	HyperTransport Multiplier	Memory Speed	Process
4122	2.2GHz	95W	4	4 x 512KB/6MB	3.2GHz	11x	1333MHz	45nm
4130	2.6GHz	95W	4	4 x 512KB/6MB	3.2GHz	13x	1333MHz	45nm
4162 EE	1.7GHz	35W	6	6 x 512KB/6MB	3.2GHz	8.5x	1333MHz	45nm
4164 EE	1.7GHz	35W	6	6 x 512KB/6MB	3.2GHz	9x	1333MHz	45nm
4170 HE	2.1GHz	65W	6	6 x 512KB/6MB	3.2GHz	10.5x	1333MHz	45nm
4174 HE	2.3GHz	65W	6	6 x 512KB/6MB	3.2GHz	11.5x	1333MHz	45nm
4176 HE	2.4GHz	65W	6	6 x 512KB/6MB	3.2GHz	12x	1333MHz	45nm

Model	Speed	Power	Cores	L2/L3 Cache	HyperTransport	HyperTransport Multiplier	Memory Speed	Process
4180	2.6GHz	95W	6	6 x 512KB/6MB	3.2GHz	13x	1333MHz	45nm
4184	2.8GHz	95W	6	6 x 512KB/6MB	3.2GHz	14x	1333MHz	45nm

5.4 Processor Configurations

The PowerEdge R415 is a two-socket server that will operate with either a single processor or dual processors. When the R415 is configured with a single processor, the memory controller is embedded in the processor and supports 4 DIMMs (1 GB minimum and a 32 GB maximum). When two processors are installed in the system, it supports a total of 8 DIMMs (2 GB minimum and a 64 GB maximum).

5.5 Processor Installation

See the Processors section in the Installing System Components chapter in the *PowerEdge R415 Hardware Owner's Manual* on Support.Dell.com.

6 Memory

6.1 Overview

The PowerEdge R415 uses DDR3 memory, providing a high-performance, high-speed memory interface capable of low-latency response and high throughput.

Key features of the R415 memory system include:

- Support for up to 128 GB of memory (8 x 16 GB RDIMMS) (16 GB DIMMS available Q1 2011)
- Two channels per processor
- Registered ECC DDR3 DIMMs or Unbuffered ECC DDR3 DIMMs
- DDR3 speeds of 1066/1333 MHz
- Single rank, dual rank, and quad rank DIMMs
- Single bit error correction
- Advanced ECC (Chipkill)
- Online spare
- Parity
- Low voltage (LV) DIMM support (6-core processor only)

6.2 DIMMs Supported

The PowerEdge R415 supports DDR3 RDIMMs and UDIMMs. The memory interface uses 1 GB, 2 GB, 4 GB, 8 GB, and 16 GB (available Q1 2011) RDIMMs and 1 GB, 2 GB, and 4 GB UDIMMs. See Table 9.

Table 9. DIMMS Supported

UDIMM	RDIMM
1GB, DDR3, 1333MHz, single rank	2GB, DDR3, 1333MHz, single rank
2GB, DDR3, 1333MHz, single rank	4GB, DDR3, 1333MHz, dual rank
4GB, DDR3, 1333MHz, dual rank	8GB, DDR3, 1333MHz, dual rank
1GB, DDR3, 1333MHz, single rank, LV	16GB, DDR3, 1066MHz, quad rank ¹
2GB, DDR3, 1333MHz, single rank, LV	2GB, DDR3, 1333MHz, single rank, LV
4GB, DDR3, 1333MHz, dual rank, LV	4GB, DDR3, 1333MHz, dual rank, LV
	8GB, DDR3, 1333MHz, dual rank, LV ¹
	16GB, DDR3, 1066MHz, quad rank, LV ¹

¹ Available Q1 2011

6.3 DIMM Slots

The DDR3 memory interface consists of two memory channels per processor socket. Each channel supports up to two RDIMMs for single/dual/quad rank or two UDIMMs. Population order is identified by the silkscreen designator and the System Information Label (SIL) located on the chassis cover.

The following DIMM population rules apply:

- Support for DDR3 1333 MHz UDIMMs or 1066/1333 MHz RDIMMs
- 2 channels, up to 2 DIMMs per channel
- Support for 1333 MHz single and dual-rank DIMMs, 1066 MHz quad-rank DIMMs

Dell

The following is not supported:

- Mixing of RDIMMs and UDIMMs
- Use of non-ECC UDIMMs

For more information on R415 memory configurations, see the System Memory section in the Installing System Components chapter in the *PowerEdge R415 Hardware Owner's Manual* on Support.Dell.com.

6.4 Speed

Each processor has two DDR3 channels capable of supporting speeds up to 1333 MHz. Single- and dual-rank DIMM types can support speeds up to 1333 MHz. Quad-rank DIMMs can support speeds up to 1066 MHz.

If memory modules with different speeds are installed, they will operate at the speed of the slowest installed memory module(s).

6.5 Sparing

Memory sparing is supported. Sparing requires a fully-populated memory configuration (8 DIMMs). See Table 10 (1 processor) and Table 11 (2 processors).

6.6 Mirroring

No mirroring support.

6.7 RAID

No RAID memory support.

6.8 Supported Configurations

Table 10. Supported Configurations (1 Processor)

System Capacity	DIMM Slots				1 Socket			
	Channel A		Channel B		UDIMM		RDIMM	
	A1	A3	A2	A4	DIMM speed	System speed	DIMM speed	System speed
1GB	1GB	—	—	—	1333	1333	N/A	N/A
2GB	1GB	—	1GB	—	1333	1333	N/A	N/A
2GB	2GB	—	—	—	1333	1333	1333	1333
4GB	1GB	1GB	1GB	1GB	1333	1333	N/A	N/A
4GB	2GB	—	2GB	—	1333	1333	1333	1333
8GB	2GB	2GB	2GB	2GB	1333	1333	1333	1333
4GB	4GB	—	—	—	1333	1333	1333	1333
8GB	4GB	—	4GB	—	1333	1333	1333	1333
16GB	4GB	4GB	4GB	4GB	1333	1066	1333	1066
16GB	8GB	—	8GB	—	N/A	N/A	1333	1333
32GB	8GB	8GB	8GB	8GB	N/A	N/A	1333	1066

System Capacity	DIMM Slots				1 Socket			
	Channel A		Channel B		UDIMM		RDIMM	
	A1	A3	A2	A4	DIMM speed	System speed	DIMM speed	System speed
32GB ¹	16GB	—	16GB	—	N/A	N/A	1066	1066
64GB ¹	16GB	16GB	16GB	16GB	N/A	N/A	1066	1066

¹ 16 GB DIMMS available Q1 2011

Table 11. Supported Configurations (2 Processors)

System Capacity	DIMM Slots				DIMM Slots				2 Socket			
	Channel A		Channel B		Channel A		Channel B		UDIMM		RDIMM	
	A1	A3	A2	A4	B1	B3	B2	B4	DIMM speed	System speed	DIMM speed	System speed
2GB	1GB	—	—	—	1GB	—	—	—	1333	1333	N/A	N/A
4GB	1GB	—	1GB	—	1GB	—	1GB	—	1333	1333	N/A	N/A
4GB	2GB	—	—	—	2GB	—	—	—	1333	1333	1333	1333
8GB	1GB	1GB	1GB	1GB	1GB	1GB	1GB	1GB	1333	1333	N/A	N/A
8GB	2GB	—	2GB	—	2GB	—	2GB	—	1333	1333	1333	1333
16GB	2GB	2GB	2GB	2GB	2GB	2GB	2GB	2GB	1333	1333	1333	1333
8GB	4GB	—	—	—	4GB	—	—	—	1333	1333	1333	1333
16GB	4GB	—	4GB	—	4GB	—	4GB	—	1333	1333	1333	1333
32GB	4GB	4GB	4GB	4GB	4GB	4GB	4GB	4GB	1333	1066	1333	1066
32GB	8GB	—	8GB	—	8GB	—	8GB	—	N/A	N/A	1333	1333
64GB	8GB	8GB	8GB	8GB	8GB	8GB	8GB	8GB	N/A	N/A	1333	1066
64GB ¹	16GB	—	16GB	—	16GB	—	16GB	—	N/A	N/A	1066	1066
128GB ¹	16GB	16GB	16GB	16GB	16GB	16GB	16GB	16GB	N/A	N/A	1066	1066

¹ 16 GB DIMMS available Q1 2011

7 Chipset

7.1 Overview

The PowerEdge R415 planar incorporates a dual-IOB configuration using the AMD SR5670 chipset with I/O bridges and the SP5100 Southbridge. The SR5670 is designed to support the AMD C32 processor family, HyperTransport-3 Interface (@ 2.6GHz), DDR3 memory technology, and PCI Express Generation 2. The chipset consists of the SR5670 and the SP5100.

7.2 AMD I/O Bridges

The PowerEdge R415 I/O board uses the AMD SR5670 I/O Bridges (IOB) to provide links between the C32 processor(s) and I/O components. The main components of the I/O controllers are configured to use two x16 HyperTransport-3 links (to both processors), up to 42 lanes of PCI Express Gen 2, an x4 PCIe Gen 1 Southbridge Interface (SB Link), and an integrated IOAPIC.

7.3 HyperTransport 3 (HT3)

The HyperTransport 3 (HT3) consists of serial point-to-point interconnects for the processors and the I/O bridges. The PowerEdge R415 has a total of four HT3 links per processor which allows interconnecting each processor with each other and an option for I/O Bridge. Each I/O Bridge has a single x16 HT3 link. A full link consists of 16 lanes (full-width) in each direction with a link speed of 6.4 GT/s. The HT3 clocking for CPU HT3 and IOB HT3 are 3.2 GHz and 2.6 GHz, respectively. Therefore, the IOB HT3 link is capable of 5.2 GT/s. For routing, the HT3 links are grouped by x8 Command Address (CAD), x1 Control (CTL), and x1 Clock (CLK) for each RX and TX directions.

7.4 Southbridge Link Interface

The Southbridge (SB) link connects the SR5670 IOB with the AMD Southbridge SP5100. The SB Link (A-Link Express) is equivalent to an x4 PCIe Gen 1 link with a transfer rate of 1 GB/s in each direction.

7.5 AMD SP5100 Southbridge (SP5100)

SP5100 is a highly-integrated southbridge controller, supporting the following functions:

- PCI bus 32-bit interface Rev 2.3 running at 33 MHz
 - Serial ATA (SATA) ports with transfer rates up to 300 MB/s (R415 supports one SATA port for optical devices)
 - Five OHC (full-speed 1.1) and two EHCI (high-speed 2.0) USB host controllers, with up to 12 USB general purpose ports and 2 USB embedded ports (R415 uses 6 ports for internal and external use from the general purpose ports)
- Power management interface (ACPI 3.0b compliant)
- Integrated Micro Controller (IMC) and thermal management
 - Note:** the iDRAC interfaces the Hardware Thermal Control (HTC), not the SP5100
- I/O interrupt controller
- SMBus 2.0 controller
- Low Pin Count (LPC) interface to Super I/O, Trusted Platform Module (TPM), and SPI-VU
- Serial Peripheral Interface (SPI) support for up to two devices
- 4 MB BIOS flash connected to the SP5100 using SPI interface

8 BIOS

8.1 Overview

The PowerEdge R415 BIOS is based on the Dell BIOS core and supports the following features:

- AMD C32 processor support
- Simultaneous Multi-Threading (SMT) support
- PCI 2.3 compliant
- Plug and Play 1.0a compliant
- Multiprocessor (MP) 1.4 compliant
- Bootable from hard drive, optical drive, iSCSI drive, USB key, and SD card
- Power-management support including DBS, power inventory, and multiple power profiles:
 - Maximum performance
 - OS control (DBS)
 - Active Power Controller
 - Custom
- ACPI 2.0 support (S0, OS-S4, S5 States)
- PXE and WOL support for on-board NICs
- Memory-sparing support
- SETUP access through <F2> key at end of POST
- USB 2.0 (USB boot code is 1.1 compliant)
- F1/F2 error logging in CMOS
- Virtual KVM, CD, and floppy support
- iDRAC supported
- Unified Server Configurator (UEFI 2.1) and UEFI shell support
- SMBIOS 2.5
- PCI-to-PCI bridge 1.0 compliant
- Dell Server Assistant 7.0 support
- System Service support
- Onboard PCI video BIOS support
- SATA enabled for CDROM and HDD
- PCI FW3.0 compliant
- I2O v1.5 ready
- Selectable boot support based on BIOS Boot Specification v1.01
- El Torito CD-ROM Boot 1.0
- Remote BIOS update support
- Remote Configuration Interface (RCI) support
- Console redirection through COM1
- PXE support based on Preboot Execution Environment Specification v2.1
- 2-byte ID support
- ePPID support in flash
- Memory remapping support
- AC recovery staggering power-up
- DIMM mismatch checking

The PowerEdge R415 BIOS does not support the following:

- BIOS language localization
- BIOS recovery after bad flash

8.2 Supported ACPI States

The following ACPI states are supported:

- ACPI compliance: S0, S4, S5
- NO S1, S2, S3 (STR)

State S4 is supported by OS support only.

8.3 Power Management Modes

8.3.1 Dell Active Power Controller

The Dell Active Power Controller (DAPC) is implemented in system BIOS and uses hardware level counters, etc., to determine hardware utilization. The BIOS uses this information to determine when to change the processor's operating frequency. The DAPC is OS independent and means that the OS no longer has control. This provides a consistent power management solution regardless of the installed OS. Some OS(s), particularly hypervisors, do not support power management, thus DAPC provides a solution when there otherwise would not be one.

8.3.2 Power Saving BIOS Setting (OS Control)

With the Power Saving BIOS setting, the OS monitors process/thread level utilization of the processor and uses processor controls to change the processor's operating frequency. For heavy workloads, the OS will run the processor at higher frequencies for additional performance. Lighter workloads do not need high performance, thus the OS will run the processor at lower frequencies.

8.3.3 Maximum Performance

The Maximum Performance mode disables power management. In this mode, the processor frequency is statically set to the highest supported frequency.

The power management features are implemented via two categories: fixed or generic.

Fixed features use bits defined in the ACPI specification for specific capabilities. The fixed-feature bits give the OS complete control over the power management of a device, since the location of the bits is given to the OS in the FACP table. Thus, a driver can directly access bits to control a device's power management.

Generic features have defined enable and status bits, but the functionality is not fully visible to the OS. Dell provides ASL code to handle the details of generic features, allowing the OS to intelligently communicate with system-specific hardware. Table 12 summarizes power management features, and Table 13 describes the possible power profiles.

Table 12. BIOS Power Management Features

Feature	Type	Enable/Status/ Ctrl bit location	Description
ACPI Mode Switch	Fixed	PCH	The OS uses the SCI_EN bit to switch from legacy mode to ACPI mode.
Sleep States	Fixed	PCH	Supported states: S0 (Working), S4-OS (Hibernation in Microsoft® Windows® 2000), and S5 (soft-off). Not supported: S1 (standby or suspend) and S3.
Power Button	Fixed	PCH	In ACPI mode, OS has control of the power button. In non-

Feature	Type	Enable/Status/ Ctrl bit location	Description
			ACPI mode, SMI handler owns power button events.
Real-Time Clock	Fixed	PCH	The OS is able to configure the system to wake on the RTC alarm.
Power Mgmt. Timer	Fixed	PCH	24-bit power management timer is used.
Power Mgmt. Event (PME)	Generic	PCH	Each host bus's PME# signal is routed to a separate general-purpose event pin in the chipset. When a device signals PME#, the system wakes (if necessary), the OS detects the event, and a Dell-defined ASL routine handles the event. Wake-on-LAN is one example of a PME.
USB Wake	Generic	N/A	This feature is not supported on this system since the S1 state is not supported.
DBS	N/A	Processor MSRs	This feature does P state transition under Microsoft® Windows®.
C State Support	N/A	Processor and PCH registers	This feature allows multiple C state supports for processor. This feature will work under Windows and ACPI OS that understand C states.
Power Profile Support	N/A	Processor/IMC and PCH chipset registers	11G Servers are the most energy-smart servers that Dell provides. In addition to P,C, and T states, BIOS exposes the power profiles to the OS. Each power profile has specific settings that fine tune processor, MCH, IOH, and Southbridge.

Table 13. BIOS Power Management Profiles

Profile	Description
Maximum Performance	DBPM Disabled (BIOS sets P-State to MAX) Memory frequency: Maximum Performance Fan algorithm: Maximum Performance
OS Control	Enable OS DBPM Control (BIOS exposes all possible P states to OS) Memory frequency: Maximum Performance Fan algorithm: Minimum Power
Active Power Controller	Enable Dell System DBPM (BIOS does not make all P states available to OS) Memory frequency: Maximum Performance Fan algorithm: Minimum Power

Profile	Description
Maximum Performance	DBPM Disabled (BIOS sets P-State to MAX) Memory frequency: Maximum Performance Fan algorithm: Maximum Performance
Custom	CPU Power and Performance Management: Maximum Performance, Minimum Power, OS DBPM, System DBPM Memory Power and Performance Management: Maximum Performance, 1333MHz, 1067MHz, 800MHz, Minimum Power Fan Algorithm: Maximum Performance, Minimum Power

9 Embedded NICs/LAN on Motherboard (LOM)

The Broadcom® 5716 LOM chip is located on the PowerEdge R415 motherboard. The 5716 chip is connected to the IOH via a PCI Express x4 gen2 link. The chip provides two 1xGB Ethernet ports with two RJ-45 connectors on the back of the system. The firmware for the LOM chip resides in a flash part. The PowerEdge R415 supports Wake-On-LAN (WOL) from either port.

10 I/O Slots

10.1 Overview

The PowerEdge R415 includes a total of two PCI Express expansion slots as follows:

- One x16 PCIe Gen2 slot for a full-height, full-length card (25W max)
- One x4 PCIe Gen1 slot for embedded SAS card only

The following requirements apply for the PCIe slots:

- Hot-plugging of PCIe cards is not supported.
- No other PCIe cards may be installed in the storage card slot, except for the dedicated SAS 6/iR modular card.

Table 14. Supported Expansion Cards

Category	Description	Width	Slot Priority	Maximum Cards
Internal Controllers	Dell PERC H700-NVD	x8 Gen2	1	1
	Dell PERC H700	x8 Gen2	1	1
	Dell PERC H200	x8 Gen2	1	1
	Dell PERC S300 Modular	x8 Gen2	2	1
	SAS 6/iR Modular	x8 Gen1	2	1
External Controllers	Dell 6Gbps SAS HBA	x8 Gen2	1	1
	Dell PERC H700-512M-NVD	x8 Gen2	1	1
	Dell PERC H700-1GB-NVD	x8 Gen2	1	1
	Dell PERC H800-512M-NVD	x8 Gen2	1	1
	Dell PERC H800-1GB-NVD	X8 Gen2	1	1
FC8 Dual Port	Qlogic® QLE2562 8Gbps FC HBA, Dual Port	x8 Gen1/x4 Gen2	1	1
	Emulex® LPe12002 8Gbps FC HBA, Dual Port	x8 Gen1/x4 Gen2	1	1
	Brocade® Dual-Port, 8 Gbps, PCIe	X8 Gen 2	1	1
FC8 Single Port	Emulex® LPe12000 8Gbps FC HBA, Single Port	x8 Gen1/x4 Gen2	1	1
	Qlogic® QLE2560 8Gbps FC HBA Single Port	X8 Gen 2	1	1
	Brocade® Single Port, 8Gbps, PCIe	X8 Gen 2	1	1
Fibre Channel	Emulex® LPe11002 FC4 HBA, Dual Port	x4 Gen1	1	1
	Emulex® LPe1150 FC4 HBA, Single Port	x4 Gen1	1	1
	Qlogic® QLE220 FC4 HBA, Single Port	x4 Gen1	1	1

Category	Description	Width	Slot Priority	Maximum Cards
	Qlogic® QLE2460 FC4 HBA, Single Port	x4 Gen1	1	1
	Qlogic® QLE2462 FC4 HBA, Dual Port	x4 Gen1	1	1
	Qlogic® QLE8152 8Gbps FC HBA, Dual Port	x8 Gen1/x4 Gen2	1	1
CNA	Qlogic® Dual Port 10GbE FCoE, SFP+	X8 Gen 2	1	1
	Emulex® Dual Port 10GbE, iSCSI, HBA, SFP+	X8 Gen 2	1	1
10Gb Ethernet Controllers	1020 Brocade® Dual Port 10G FCoE, SFP+, PCIe	X8 Gen 2	1	1
	Broadcom® 57712 Dual Port 10 G Base-T, PCIe	X8 Gen2	1	1
	Broadcom® NetXtreme™ II 57711 Dual-Port SFP+/Direct Attach 10GbE PCIe with TOE and iSCSI Offload	X8 Gen 2	1	1
	Intel® Dual Port 10GE Base-T, PCIe Gen 2, Sr-IOV, FCoE	X8 Gen 2	1	1
	Intel® Ethernet X520 DA2 Dual-Port 10Gb Server Adapter	X8 Gen 2	1	1
	Intel® X520-T2 Dual-Port 10GbE Server Adapter	X8 Gen 2	1	1
	Emulex® OCE10102FXD, 10G PCIe FCoE CAN, Dual Port	X8 Gen 2	1	1
1G NICs	Intel® PCIe Quad Port Copper	x4 Gen1/Gen2	1	1
	Intel® PRO/1000PT 1G Cu Single Port NIC	x1 Gen1	1	1
	Broadcom® 5709 IPv6 1G Cu Dual Port NIC TOE	x4 Gen1	1	1
	Broadcom® 5709 IPV6 1G CU Dual Port NIC TOE/iSOE	x4 Gen1	1	1
	Intel® PCIe Dual Port Copper	x4 Gen1/Gen2	1	1
	Broadcom® 5709 Quad Port, LP & FH bracket, ToE, iSoE	X4 Gen2	1	1

For more information on PCIe cards, see Expansion Cards and Expansion-Card Risers in the Installing System Components chapter in the *PowerEdge R415 Hardware Owner's Manual* on Support.Dell.com.

10.2 Boot Order

The boot order can be customized based on bootable devices detected by the BIOS.

10.3 NICs

See details in the table above.

10.4 NIC and LOM Enumeration

LOMs will enumerate first in order to have consistent Ethernet assignment (i.e., eth0). NIC enumeration varies depending on configuration.

10.5 PCI Card Dimensions

For information about PCI slots and card dimensions, see the Back-Panel Features and Indicators section in the About Your System chapter in the *PowerEdge R415 Hardware Owner's Manual* on [Support.Dell.com](https://support.dell.com).

11 Storage

11.1 Overview

The PowerEdge R415 supports up to four hard drives in one of the following configurations:

- 4 x 3.5" cabled SATA from motherboard SATA connector
- 4 x 3.5" cabled SAS or SATA with add-on storage controller
- 4 x 3.5" hot-swap SAS or SATA with add-on storage controller
- 4 x 2.5" hot-swap SAS or SATA or SSD with add-on storage controller

The 2.5" hard drive requires a hot-plug configuration with the 3.5" hard drive carrier and retention kit. After a chassis configuration is chosen (cabled or hot-plug) there is not an available upgrade option. See Table 15.

Table 15. Supported Hard Drives

Form Factor	Capacity	Speed	Type	Cabled or Hot-plug
3.5"	160GB, 250GB, 500GB, 1TB, 2TB	7.2K	SATA	Both
3.5"	500GB, 1TB, 2TB	7.2K	NL SAS	1TB: cabled only
3.5"	146GB	15K	SAS 3GB	Both
3.5"	300GB, 450GB, 600GB	15K	SAS 6GB	Both
2.5"	146GB, 300GB, 600GB	10K	SAS	All: hot-plug only (with HDD carrier)
2.5"	50GB	N/A	SSD	Both

11.2 RAID Configurations

Table 16 details RAID configurations for the PowerEdge R415.

Table 16. RAID Configurations

Factory Configuration					Non-Mixed drives all SATA, all SAS, or all SSD; all 2.5" or all 3.5"	
Cabled/ Hot Plug	Config Type	Configs		Description	Min HDD	Max HDD
Cabled	Embedded SATA	C1	MSTCBL	On-board SATA controller (AMD SR5670)	1	4
Cabled	SAS/SATA No RAID	C2	ASSCBL	Add-in SAS/SATA RAID card, no RAID (SAS 6/iR or PERC H200)	1	4
Cabled	SAS/SATA RAID	C3	ASSR0CBL	Add-in SAS/SATA RAID card, RAID 0 (SAS 6/iR or PERC H200 or PERC H700)	1	4
		C4	ASSR1CBL	Add-in SAS/SATA RAID card, RAID 1 (SAS 6/iR or PERC H200 or PERC H700)	2	2

Factory Configuration					Non-Mixed drives all SATA, all SAS, or all SSD; all 2.5" or all 3.5"	
Cabled/ Hot Plug	Config Type	Configs		Description	Min HDD	Max HDD
		C5	ASSR5CBL	Add-in SAS/SATA RAID card, RAID 5 (PERC H700)	3	4
		C6	ASSR6CBL	Add-in SAS/SATA RAID card, RAID 6 (PERC H700)	4	4
		C7	ASSR10CBL	Add-in SAS/SATA RAID card, RAID 10 (PERC H200 or H700)	4	4
		C8	ASSR5CBL	Add-in SAS/SATA RAID card, RAID 5 (PERC S300)	3	4
		C9	ASSR10CBL	Add-in SAS/SATA RAID card, RAID 10 (PERC S300)	4	4
Cabled/ Hot Plug	Config Type	Configs		Description	Min HDD	Max HDD
Hot Plug	SAS/SATA/SSD No RAID	C10	ASS	Add-in SAS/SATA RAID card, No RAID (SAS 6/iR or PERC H200)	1	4
Hot Plug	SAS/SATA/SSD RAID	C11	ASSR0	Add-in SAS/SATA RAID card, RAID 0 (SAS 6/iR or PERC H200 or PERC H700)	1	4
		C12	ASSR1	Add-in SAS/SATA RAID card, RAID 1 (SAS 6/iR or PERC H200 or PERC H700)	2	2
		C13	ASSR5	Add-in SAS/SATA RAID card, RAID 5 (PERC H700)	3	4
		C14	ASSR6	Add-in SAS/SATA RAID card, RAID 6 (PERC H700)	4	4
		C15	ASSR10	Add-in SAS/SATA RAID card, RAID 10 (PERC H200 or H700)	4	4
Hot Plug	SAS/SATA RAID	C16	ASSR5	Add-in SAS/SATA RAID card, RAID 5 (PERC S300)	3	4
		C17	ASSR10	Add-in SAS/SATA RAID card, RAID 10 (PERC S300)	4	4
Hot Plug	SAS/SATA/SSD RAID 1 + RAID 1	C18	ASSR1R1	Add-in SAS/SATA/RAID card, RAID 1 + RAID 1 (SAS 6/iR or PERC H200 or PERC H700)	2+2	2+2
Mixed HDD (SAS + SATA) Factory Configuration					Mixed SAS + SATA Min: 2xSAS+1xSATA Max: 2xSAS+2xSATA; all 2.5" or 3.5"	
Hot Plug	Mix SAS and SATA No RAID	C19	ASS-X	Add-in SAS/SATA RAID card, no RAID (SAS 6/iR or PERC H200)	2 x SAS + 1 x SATA	2 x SAS + 1 x SATA

Factory Configuration				Non-Mixed drives all SATA, all SAS, or all SSD; all 2.5" or all 3.5"		
Cabled/ Hot Plug	Config Type	Configs		Description	Min HDD	Max HDD
Hot Plug	Mix SAS and SATA RAID	C20	ASSR1R1-X	Add-in SAS/SATA/RAID card, RAID 1 + RAID 1 (SAS 6/iR or PERC H200 or PERC H700)	2 x SAS + 2 x SATA	2 x SAS + 2 x SATA

Additional restrictions for RAID configurations are as follows:

- SSD support requires H200 or H700. SAS 6i/R and PERC S300 do not support SSD.
- Hard drives must be all 2.5" or 3.5".

PERC S300 does not support the following virtualization solutions:

- Microsoft® Hyper-V™ server 2008 x64 (download version)
- Microsoft® Windows Server® 2008 x64 (Hyper-V™ role enabled)
- Microsoft® Windows Server® 2008 SP2 x64 (Hyper-V™ role enabled)
- Microsoft® Windows Server® 2008 R2 (Microsoft® Windows® 7 includes SP2 bits) x64 (Hyper-V™ role enabled)

PERC S300 does not support Linux® operating systems or VMware® virtualization software.

11.3 LED Indicators

Each disk drive carrier has two LED indicators visible from the front of the system. One is a green LED for disk activity and the other is a bicolor (green/amber) LED for status information. The activity LED is driven by the disk drive during normal operation. The bicolor LED is controlled by the SEP device on the backplane. Both LEDs are used to indicate certain conditions under direction of a storage controller.

For more information, see the Hard-Drive Indicator Patterns section in the About Your System chapter in the *PowerEdge R415 Hardware Owner's Manual* on Support.Dell.com.

11.4 Optical Drives

The PowerEdge R415 supports one SATA interface, DVD-ROM or DVD+/-RW.

11.5 Tape Drives

External tape drives and tape libraries are supported. No internal tape drive support is available.

For more information on supported tape drives and tape libraries, see <http://www.dell.com/storage>.

11.6 External Storage

External storage devices are supported. For more information, see <http://www.dell.com/storage>.

12 Video

The PowerEdge R415 is equipped with a Matrox® G200eW with 8 MB memory integrated in the Nuvoton® WPCM450 (BMC controller). Supported resolutions are listed in Table 17.

Table 17. Graphics Video Modes

Resolution	Refresh Rate (Hz)	Color Depth (bit)
640 x 480	60, 72, 75, 85	8, 16, 32
800 x 600	60, 72, 75, 85	8, 16, 32
1024 x 768	60, 72, 75, 85	8, 16, 32
1152 x 864	75	8, 16, 32
1280 x 1024 ¹	60	32
1280 x 1024 ²	60, 75, 85	8, 16
¹ 32 bit color only supported at 60Hz for this resolution. ² 85Hz for KVM and 1600x1200 at 60Hz for video out.		

13 Rack Information

13.1 Overview

The ReadyRails™ sliding and static rail systems for the R415 provide toolless support for 4-post racks with square or unthreaded round mounting holes including all generations of Dell racks. Both support tooled mounting in 4-post threaded racks (an optional adapter brackets kit is required for the sliding rails), with the static rails also providing tooled mounting support for 2-post (Telco) racks for added versatility. The optional cable management arm (CMA) can be mounted on either the left or right side of the sliding rails without the use of tools for fast and easy deployment.

Note: The PowerEdge R415 is not compatible with any other Dell rails including previous generation rails, but it does use the same sliding rails as the R310 and R410 and uses the same static rails as the R210, R310, and R410.

13.2 Rails

The rail offerings for the R415 consist of two types: sliding rails and static rails.

13.2.1 Sliding Rails

Sliding rails allow the system to be fully extended out of the rack for service, and are available with or without the optional cable management arm (CMA). See Figure 18.

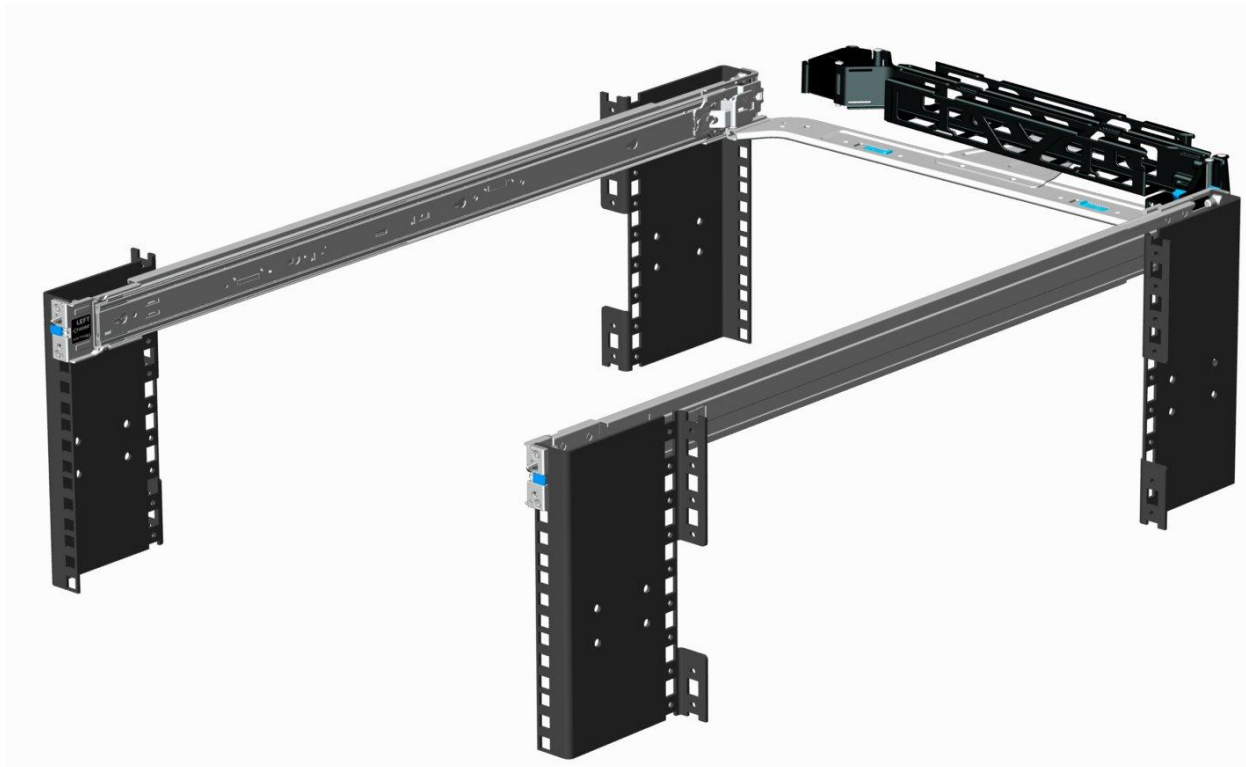

Figure 18. R415 Sliding Rails with Optional CMA

Sliding rail kits can be used in a threaded hole rack only if threaded rack adapter brackets are installed. The threaded rack adapter brackets are first mounted to the EIA flanges in the rack, and then the sliding rails

Dell

are mounted into the brackets. The design of the brackets has been optimized to limit the forward shift of the system in the rack to only 17.3 mm.

The adapter brackets kit includes six brackets to accommodate different rail lengths, plus four sets of custom screws in common thread sizes. See Figure 19. A detailed Getting Started Guide is included in the kit along with directions for installing the brackets and mounting the rails into the brackets.

Depending on the depth of the rack used, it may be necessary to remove the server's bezel in order to close the door of the rack. A minimum of 58 mm will be needed between the back surface of the door panel and the front face of the EIA flange for the front door to close with the 11G server bezel installed.



Figure 19. 1U Threaded Rack Adapter Brackets Kit

13.2.2 Static Rails

Static rails support a wider variety of racks than the sliding rails, but do not support serviceability in the rack and are thus not compatible with the CMA. See Figure 20.

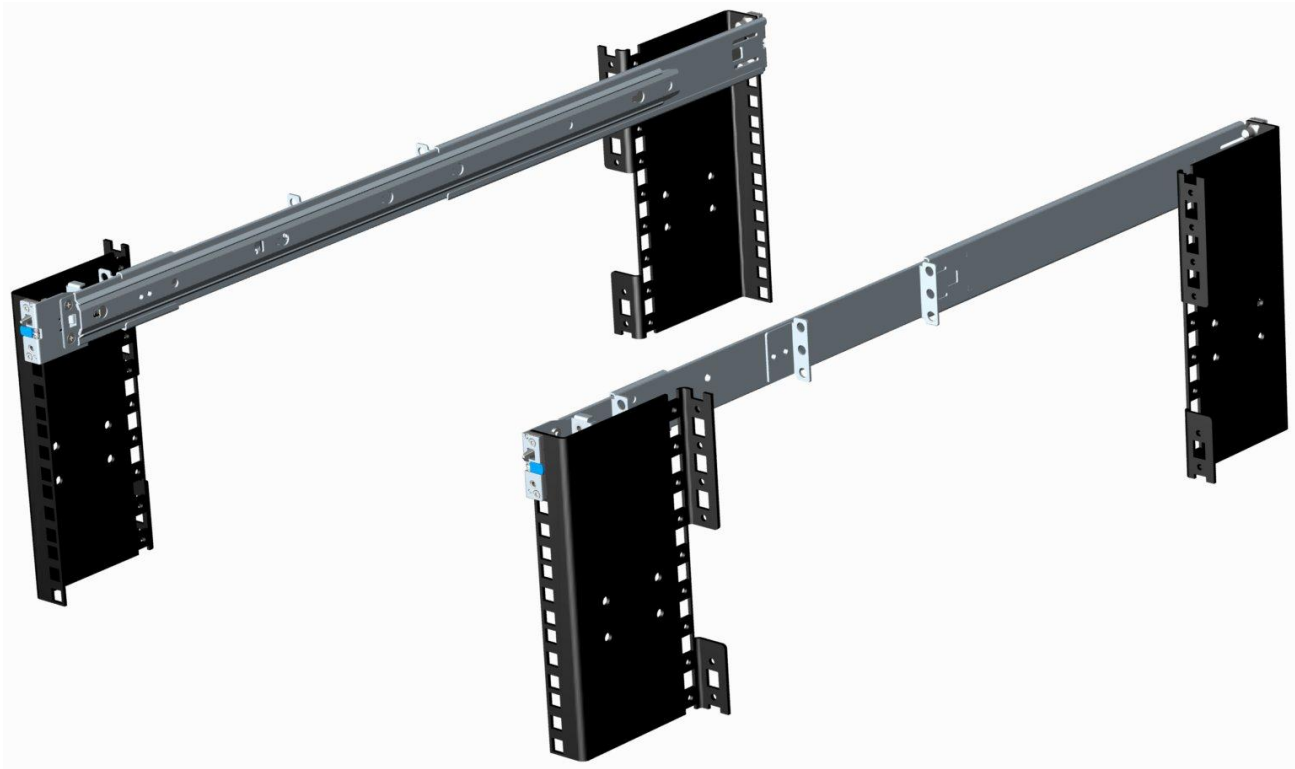

Figure 20. R415 Static Rails

One key factor in selecting the proper rails is identifying the type of rack in which they will be installed. Both the sliding rails and the static rails support mounting in 19”-wide, EIA-310-E compliant 4-post racks, but only the static rails support mounting in 2-post (Telco) racks.

Table 18 provides a summary of the rack types supported by the R415 rails.

Table 18. Supported Racks

Product	Rail ID	Mounting Interface	Rail Type	Rack Types Supported				
				4-Post			2-Post	
				Square	Round	Thread	Flush	Center
R415	A3	ReadyRails	Sliding	✓	✓	✓*	✗	✗
	A4	ReadyRails/Generic	Static	✓	✓	✓	✓	✓

*Requires the 1U Threaded Rack Adapter Brackets Kit (Dell PN 8Y19G)

Screws are not included in the static rail kit since the threaded racks are offered with a variety of thread designations. Users must provide their own screws when mounting the static rails in threaded or 2-post racks.

Other factors to consider in rail selection include the spacing between the front and rear mounting flanges of the rack, the type and location of any equipment mounted in the back of the rack such as power distribution units (PDUs), and the overall depth of the rack. See Table 19.

Due to their reduced complexity and lack of need for CMA support, the static rails offer a greater adjustability range and an overall smaller footprint than the sliding rails.

Table 19. Rail Adjustability Ranges and Depth

Product	Rail ID	Mounting Interface	Rail Type	Rail Adjustability Range (mm)						Rail Depth (mm)	
				Square		Round		Threaded		without CMA	with CMA
				Min	Max	Min	Max	Min	Max		
R415	A3	ReadyRails	Sliding	686	883	672	876	651	897	714	835
	A4	ReadyRails/ Generic	Static	608	879	594	872	604	890	622	N/A

The adjustment range of the rails is a function of the type of rack in which they are being mounted. The min-max values listed above represent the allowable distance between the front and rear mounting flanges in the rack. Rail depth represents the minimum depth of the rail as measured from the rack front mounting flanges when the rail rear bracket is positioned all the way forward.

13.3 Cable Management Arm (CMA)

The optional cable management arm (CMA) for the R415 organizes and secures the cords and cables exiting the back of the server and unfolds to allow the server to extend out of the rack without having to detach the cables. Some key features of the R415 CMA include:

- Large U-shaped baskets support dense cable loads.
- An open-vent pattern allows optimal airflow.
- The CMA mounting is fully-reversible (can be mounted on either side) with no conversion required.
- Hook-and-loop straps are used (rather than plastic tie wraps) to eliminate the risk of cable damage during cycling.
- A low-profile fixed tray is included to support and retain the CMA in its fully-closed position.
- The CMA and the tray can be mounted without the use of tools using simple and intuitive snap-in designs.

14 Operating Systems and Virtualization

For detailed information, see the following:

- [Operating System Support Matrix for Dell PowerEdge Systems](#) on www.Dell.com
- *Dell PowerEdge R415 Systems Getting Started With Your System* guide on Support.Dell.com

15 Systems Management

15.1 Overview/Description

Dell aims on delivering open, flexible, and integrated solutions that help you reduce the complexity of managing disparate IT assets by building comprehensive IT management solutions. Combining Dell PowerEdge Servers with a wide selection of Dell-developed management solutions gives you choice and flexibility, so you can simplify and save in environments of any size. To help you meet your server performance demands, Dell offers Dell OpenManage™ systems management solutions for:

- Deployment of one or many servers from a single console
- Monitoring of server and storage health and maintenance
- Update of system, operating system, and application software

Dell offers IT management solutions for organizations of all sizes—priced, sized, and supported right.

15.2 Server Management

A Dell Systems Management and Documentation DVD and a Dell Management Console DVD are included with the product. ISO images are also available. A brief description of available content:

- **Dell Systems Build and Update Utility:** Dell Systems Build and Update Utility assists in OS install and pre-OS hardware configuration and updates.
- **OpenManage Server Administrator:** The OpenManage Server Administrator (OMSA) tool provides a comprehensive, one-to-one systems management solution, designed for system administrators to manage systems locally and remotely on a network. OMSA allows system administrators to focus on managing their entire network by providing comprehensive one-to-one systems management.
- **Management Console:** Our legacy IT Assistant console is also included, as well as tools to allow access to our remote management products. These tools are Remote Access Service, for iDRAC, and the BMC Management Utility.
- **Active Directory Snap-in Utility:** The Active Directory Snap-in Utility provides an extension snap-in to the Microsoft Active Directory. This allows you to manage Dell specific Active Directory objects. The Dell-specific schema class definitions and their installation are also included on the DVD.
- **Dell Systems Service Diagnostics Tools:** Dell Systems Service and Diagnostics tools deliver the latest Dell optimized drivers, utilities, and operating system-based diagnostics that you can use to update your system.
- **eDocs:** The section includes PDF files for PowerEdge systems, storage peripheral, and OpenManage software.
- **Dell Management Console DVD:** The Dell Management Console is a Web-based systems management software that enables you to discover and inventory devices on your network. It also provides advanced functions, such as health and performance monitoring of networked devices and patch management capabilities for Dell systems.
- **Server Update Utility:** In addition to the Systems Management Tools and Documentation and Dell Management Console DVDs, customers have the option to obtain Server Update Utility DVD. This DVD has an inventory tool for managing updates to firmware, BIOS and drivers for either Linux or Windows varieties.

15.3 Embedded Server Management

The PowerEdge R415 implements circuitry for the next generation of Embedded Server Management. It is Intelligent Platform Management Interface (IPMI) v2.0 compliant. The optional iDRAC (Integrated Dell

Dell

Remote Access Controller) is responsible for acting as an interface between the host system and its management software and the peripheral devices. These peripheral devices consist of the PSUs, the storage backplane, integrated SAS HBA or PERC 6/I, and control panel with display.

The optional upgrade to iDRAC6 provides features for managing the server remotely or in data center lights-out environments.

Advanced iDRAC features require the installation of the optional iDRAC6 Enterprise card.

15.4 Lifecycle Controller and Unified Server Configurator

Embedded management is comprised of several interdependent pieces:

- Lifecycle Controller
- Unified Server Configurator
- iDRAC6
- vFlash

Lifecycle controller powers the embedded management features. It is integrated and tamperproof storage for system-management tools and enablement utilities (firmware, drivers, etc.). It is flash partitioned to support multiple, future-use cases.

Dell Unified Server Configurator (USC) is a local 1:1 graphical user interface embedded on Lifecycle Controller that aids in local server provisioning in a pre-OS environment. For servers with iDRAC Express, the Lifecycle Controller offers OS install, platform updates, platform configuration, and diagnostics capabilities. For servers without iDRAC Express, this utility has limited functionality and offers OS install and diagnostics capabilities only.

To access the Unified Server Configurator, press the <F10> key within 10 seconds of the Dell logo's appearance during the system boot process. Current functionality enabled by the Unified Server Configurator includes:

Table 20. Unified Server Configurator Features and Description

Feature	Description
Faster O/S Installation	Drivers and the installation utility are embedded on system, so no need to scour DELL.COM
Faster System Updates	Integration with Dell support automatically directed to latest versions of the Unified Server Configurator, iDRAC, RAID, BIOS, NIC, and Power Supply
Update Rollback	Ability to recover to previous "known good state" for all updatable components
More Comprehensive Diagnostics	Diagnostic utilities are embedded on system
Simplified Hardware Configuration	Detects RAID controller and allows user to configure virtual disk and choose virtual disk as boot device, eliminating the need to launch a separate utility. Also provides configuration for iDRAC, BIOS, and NIC/LOM.

15.5 iDRAC Express

The optional iDRAC Express is the first tier of iDRAC6 upgrades. In addition to upgrading the system with a Lifecycle Controller, the iDRAC6 Express offers the following key features:

Dell

- Graphical web interface
- Standard-based interfaces
- Server Sensor monitoring and fault alerting
- Secure operation of remote access functions including authentication, authorization, and encryption
- Power control and management with the ability to limit server power consumption and remotely control server power states
- Advanced troubleshooting capabilities

For more information on iDRAC6 Express features see Table 21.

15.6 iDRAC6 Enterprise

The optional iDRAC6 Enterprise card provides access to advanced iDRAC6 features. The iDRAC6 Enterprise connects directly to the R415 planar and is mounted parallel to the planar with stand-offs.

Key features for the iDRAC6 Enterprise include:

- Scripting capability with Dell’s Racadm command-line
- Remote video, keyboard, and mouse control with Virtual Console
- Remote media access with Virtual Media
- Dedicated network interface

Additionally, the iDRAC6 Enterprise can be upgraded by adding the vFlash Media card. This is a 1 GB Dell branded SD card that enables a persistent 256 MB virtual flash partition. In the future, vFlash will be expanded to include additional features.

A more detailed feature list for iDRAC6 Enterprise and vFlash is included in Table 21.

Table 21. Features List for BMC, iDRAC, and vFlash

Feature	BMC	iDRAC6 Express	iDRAC6 Enterprise	vFlash Media
Interface and Standards Support				
IPMI 2.0	✓	✓	✓	✓
Web-based GUI		✓	✓	✓
SNMP		✓	✓	✓
WSMAN		✓	✓	✓
SMASH-CLP		✓	✓	✓
Racadm command-line			✓	✓
Conductivity				
Shared/Failover Network Modes	✓	✓	✓	✓
IPv4	✓	✓	✓	✓
VLAN Tagging	✓	✓	✓	✓
IPv6		✓	✓	✓
Dynamic DNS	✓	✓	✓	✓
Dedicated NIC			✓	✓

Dell

Feature	BMC	iDRAC6 Express	iDRAC6 Enterprise	vFlash Media
Security and Authentication				
Role-based Authority	✓	✓	✓	✓
Local Users	✓	✓	✓	✓
Active Directory		✓	✓	✓
SSL Encryption		✓	✓	✓
Remote Management and Remediation				
Remote Firmware Update	✓	✓	✓	✓
Server power control	✓	✓	✓	✓
Serial-over-LAN (with proxy)	✓	✓	✓	✓
Serial-over-LAN (no proxy)		✓	✓	✓
Power capping		✓	✓	✓
Last crash screen capture		✓	✓	✓
Boot capture		✓	✓	✓
Serial-over-LAN		✓	✓	✓
Virtual media			✓	✓
Virtual console			✓	✓
Virtual console sharing			✓	✓
Virtual flash				✓
Monitoring				
Sensor Monitoring and Alerting	✓	✓	✓	✓
Real-time Power Monitoring*	✓	✓	✓	✓
Real-time Power Graphing*	✓	✓	✓	✓
Historical Power Counters*	✓	✓	✓	✓
Logging Features				
System Event Log	✓	✓	✓	✓
RAC Log		✓	✓	✓
Trace Log			✓	✓

16 USB Peripherals

The PowerEdge R415 supports the following USB devices:

- USB key (bootable)
- Keyboard (only one USB keyboard is supported)
- Mouse (only one USB mouse is supported)
- Optional USB DVD-ROM

Appendix A. Statement of Volatility

The Dell PowerEdge R415 contains both volatile and non-volatile (NV) components. Volatile components lose their data immediately upon removal of power from the component. Non-volatile components continue to retain their data even after the power has been removed from the component. Components chosen as user-definable configuration options (those not soldered to the motherboard) are not included in the Statement of Volatility. Configuration option information (pertinent to options such as microprocessors, system memory, remote access controllers, and storage controllers) is available by component separately. The NV components detailed in Table 22 are present in the PowerEdge R415 server.

Table 22. R415 Volatility Table

Server BIOS Memory	Details
Size:	32Mbit
Type [e.g., Flash PROM, EEPROM]:	Flash EEPROM
Can user programs or operating system write data to it during normal operation?	No
Purpose? [e.g., boot code]	Boot Code and Configuration Information
How is data input to this memory?	Loading flash memory requires a vendor provided firmware file and loader program which is executed by booting up the system from a floppy or OS based executable containing the firmware file and the loader. System loaded with arbitrary data in firmware memory would not operate.
How is this memory write protected?	Software write protected
Server CMOS (Complementary Metal-Oxide Semiconductor) Memory	Details
Size:	512 bytes
Type: [e.g., Flash PROM, EEPROM]:	Battery backed NVRAM
Can user programs or operating system write data to it during normal operation?	No
Purpose? [e.g., boot code]	RTC and configuration settings
How is data input to this memory?	F2 Setup Menu during POST
How is this memory write protected?	N/A
Remarks	Jumper on motherboard can be used to clear to factory default settings

LOM (LAN [Network Interface] on Motherboard) Memory	Details
Size:	4Mb (1MB)
Type: [e.g., Flash PROM, EEPROM]:	Flash
Can user programs or operating system write data to it during normal operation?	Yes, under software control
Purpose? [e.g., boot code]	Contains LOM boot code and config data
How is data input to this memory?	Requires vendor provided firmware file and loader program used during factory assembly or possible field update. A system loaded with arbitrary data in firmware memory would not operate.
How is this memory write protected?	Software control
Server System FRU	Details
Size:	4KB
Type: [e.g., Flash PROM, EEPROM]:	SEEPROM
Can user programs or operating system write data to it during normal operation?	No
Purpose? [e.g., boot code]	Store System FRU
How is data input to this memory?	BMC controller write
How is this memory write protected?	Not write protected
Power Supply FRU	Details
Size:	256 bytes
Type: [e.g., Flash PROM, EEPROM]:	SEEPROM
Can user programs or operating system write data to it during normal operation?	No
Purpose? [e.g., boot code]	Store power supply information
How is data input to this memory?	Programmed by the power supply manufacturer.
How is this memory write protected?	Not write protected

TPM (Trusted Platform Module; For boards shipped outside of China; Boards sold to destinations in China do not have TPM at this time)	Details
Size:	Unspecified size of user ROM, RAM, EEPROM; 128 bytes of OTP memory included
Type: [e.g., Flash PROM, EEPROM]:	ROM, RAM, EEPROM
Can user programs or operating system write data to it during normal operation?	Yes, operating systems and applications that conform to the TCG standard can write data to the TPM during normal operation. Access to the NV Storage is controlled by the TPM owner.
Purpose? [e.g., boot code]	Trusted Platform Module NV storage. May be used to securely storage of encryption keys.
How is data input to this memory?	TCG TPM Specification defined command interface or Using TPM Enabled operating systems
How is this memory write protected?	As defined by the TCG TPM Specification, protection of this NV memory area is configurable by the TPM owner.
Backplane Firmware and FRU	Details
Size:	32KB
Type: [e.g., Flash PROM, EEPROM]:	Flash
Can user programs or operating system write data to it during normal operation?	No
Purpose? [e.g., boot code]	Backplane Firmware and FRU data storage
How is data input to this memory?	Loading flash memory requires a vendor provided firmware file and loader program which is executed by booting up the system from a floppy or OS based executable containing the firmware file and the loader. System loaded with arbitrary data in firmware memory would not operate.
Embedded Bootable Memory Device	Details
Size:	1GB
Type: [e.g., Flash PROM, EEPROM]:	MMC
Can user programs or operating system write data to it during normal operation?	Yes
Purpose? [e.g., boot code]	Optional embedded boot device
How is data input to this memory?	Factory installed or via USB bus
How is this memory write protected?	Not write protected

Server BMC (Baseboard Management Controller) Firmware Flash Memory	Details
Size:	16MB Flash
Type: [e.g., Flash PROM, EEPROM]:	SPI Flash
Can user programs or operating system write data to it during normal operation?	No
Purpose? [e.g., boot code]	Stores the BMC Firmware
How is data input to this memory?	Loading flash memory requires a vendor provided firmware file and loader program which is executed by booting up the system from a floppy or OS based executable containing the firmware file and the loader. System loaded with arbitrary data in firmware memory would not operate.
How is this memory write protected?	Software write protected

To obtain optional component information, please refer to the Dell Statement of Volatility for the individual components. Please direct any questions to your Dell Marketing contact.

Appendix B. Certifications

B.1 Regulatory Certifications

Regulatory model: E07S

Regulatory Type: E07S003

Regulatory compliance information can be located at the following sites:

- [Product Safety, EMC and Environmental Datasheets](#)
- [Dell Regulatory Compliance Home Page](#)

B.2 Product Safety Certifications

The product has been certified and bears the Mark, as applicable, of the Product Safety authorities as indicated in Table 23.

Table 23. Product Safety Certifications

Country/Region	Authority or Mark
Argentina	IRAM
Belarus	BELLIS
Canada	SCC
China	CNCA or CCC
Croatia	KONCAR
European Union	CE
Germany	TUV
IECEE	IECEE CB
Israel	SII
Kazakhstan	OTAN - CKT
Kenya	KEBS
Kuwait	KUCAS
Mexico	NYCE or NOM
Moldova	INSM
Nigeria	SONCAP
Norway	NEMKO
Russia	GOST
Saudi Arabia	KSA ICCP
South Africa	NRCS
Taiwan	BSMI
Ukraine	UKRTEST or UKRSERTCOMPUTER
United States	NRTL
Uzbekistan	STZ

B.3 Electromagnetic Compatibility

The product has been certified and bears the Mark, as applicable, of the EMC authorities as indicated in Table 24.

Table 24. Electromagnetic Compatibility Certifications

Country/Region	Authority or Mark	Class
Australia/New Zealand	ACMA or C-Tick	Class A
Belarus	BELLIS	Class A
Bosnia & Herzegovina, Montenegro, Serbia	KVALITET	Class A
Canada	ICES	Class A
China	CNCA or CCC	Class A
Croatia	KONCAR	Class A
European Union	CE	Class A
Israel	SII	Class A
Japan	VCCI	Class A
Kazakhstan	OTAN - CKT	Class A
Moldova	INSM	Class A
Norway	NEMKO	Class A
Russia	GOST	Class A
South Africa	SABS	Class A
South Korea	KCC	Class A
Taiwan	BSMI	Class A
Ukraine	UKRTEST or UKRSERTCOMPUTER	Class A
United States	FCC	Class A
Uzbekistan	STZ	Class A
Vietnam	ICT	Class A

B.4 Ergonomics, Acoustics and Hygienics

The product has been certified and bears the Mark, as applicable, of the Ergonomics, Acoustics, and Hygienics authorities as indicated in Table 25.

Table 25. Ergonomics, Acoustics and Hygienics

Country/Region	Authority or Mark
Belarus	BELLIS
Germany	GS
Russia	GOST

Appendix C. Additional Information and Options

The PowerEdge R415 system conforms to the industry standards detailed in Table 26.

Table 26. Industry Standards

Standard	URL for information and specifications
ACPI Advance Configuration and Power Interface Specification, v2.0c	http://www.acpi.info/
Energy Star EPA Version 1.0 of the Computer Server specification	http://www.energystar.gov/index.cfm?c=archives.enterprise_servers
Ethernet IEEE 802.3-2005	http://standards.ieee.org/getieee802/802.3.html
IPMI Intelligent Platform Management Interface, v2.0	http://www.intel.com/design/servers/ipmi/
DDR3 Memory DDR3 SDRAM Specification, Rev. 3A	http://www.jedec.org/download/search/JESD79-3A.pdf
LPC Low Pin Count Interface Specification, Rev. 1.1	http://developer.AMD.com/design/chipsets/industry/lpc.htm
PCI Express PCI Express Base Specification Rev. 2.0	http://www.pcisig.com/specifications/pciexpress/
PMBus Power System Management Protocol Specification, v1.1	http://pmbus.info/specs.html
SAS Serial Attached SCSI, v1.1	http://www.t10.org/cgi-bin/ac.pl?t=f&f=sas1r10.pdf
SATA Serial ATA Rev. 2.6; SATA II, Extensions to SATA 1.0a, Rev. 1.2	http://sata-io.org/
SMBIOS System Management BIOS Reference Specification, v2.6	http://www.dmtf.org/standards/smbios/
TPM Trusted Platform Module Specification, v1.2	http://www.trustedcomputinggroup.org/resources/tpm_main_specification
UEFI	http://www.uefi.org/specs/

Standard	URL for information and specifications
Unified Extensible Firmware Interface Specification, v2.1	
USB Universal Serial Bus Specification, Rev. 2.0	http://www.usb.org/developers/docs/
Windows Logo Windows Logo Program System and Device Requirements, v3.10	http://www.microsoft.com/whdc/winlogo/hwrequirements.msp