

HP StorageWorks 70 Modular Smart Array Enclosure maintenance and service guide

This guide provides procedures and diagnostics needed for the maintenance and troubleshooting of the HP StorageWorks 70 Modular Smart Array Enclosure.

March 2007 (Third Edition)
Part Number 434895-003



© Copyright 2007 Hewlett-Packard Development Company, L.P.

The information contained herein is subject to change without notice. The only warranties for HP products and services are set forth in the express warranty statements accompanying such products and services. Nothing herein should be construed as constituting an additional warranty. HP shall not be liable for technical or editorial errors or omissions contained herein.

Windows is a U.S. registered trademark of Microsoft Corporation.

February 2007 (First Edition)

Part Number 434895-003

Contents

About this guide	6
Intended audience	6
Prerequisites	6
Document conventions and symbols	6
HP technical support	7
Product warranties	7
Subscription service	8
HP websites	8
Documentation feedback	8
Illustrated parts catalog	9
System components	9
Specifications	11
Environmental specifications	11
Enclosure specifications	11
Supported cables	12
Identifying components	13
Front panel components	13
Front panel LEDs	14
Rear panel components	14
Rear panel LEDs	15
Hard drive bay numbers	16
Hard drive LEDs	16
Hard drive LED combinations	17
Diagnostic tools	18
Integrated Management Log	18
Array Diagnostic Utility	18
Customer replaceable components	19
Overview of removal and replacement procedures	19
Customer self repair	19
Parts only warranty service	20
Procuring the spare component	20
Returning the defective component	20
Recommended tools	21
Warnings and precautions	21
Electrostatic discharge information	21
Grounding methods	21
Equipment symbols	22
Weight warning	22
Rack warnings and precautions	22
Device warnings and precautions	23
Removal and replacement procedures	25
Powering up and powering down	25
Powering up	25
Powering down	26
Access panel	26
Removing the access panel	26

Installing the access panel	27
Hard drive blank	27
Removing the hard drive blank	27
Installing the hard drive blank	27
Hot-plug hard drive	28
Before you begin	28
Verifying component failure	28
Removing the hard drive	29
Installing the hard drive	30
Verifying component replacement	30
Hot-plug power supply	30
Before you begin	30
Verifying component failure	31
Removing the power supply	31
Installing the power supply	31
Verifying component replacement	31
Hot-plug fan	32
Before you begin	32
Verifying component failure	32
Removing the fan	32
Installing the fan	32
Verifying component replacement	33
I/O module	33
Before you begin	33
Verifying component failure	33
Removing the I/O module	33
Installing the I/O module	34
Verifying component replacement	34
Front UID module	34
Before you begin	34
Verifying component failure	34
Removing the front UID module	35
Installing the front UID module	35
Verifying component replacement	35
Power on/off module	36
Before you begin	36
Verifying component failure	36
Removing the power on/off module	36
Installing the power on/off module	38
Verifying component replacement	38
Power UID module	39
Before you begin	39
Verifying component failure	39
Removing the power UID module	39
CAUTION:	40
Installing the power UID module	40
Verifying component replacement	40
7-segment display board	41
Before you begin	41
Verifying component failure	41
Removing the 7-segment display board	41
Installing the 7-segment display board	42
Verifying component replacement	42

Riser board	43
Before you begin	43
Verifying component failure	43
Removing the riser board.....	43
Installing the riser board	45
Verifying component replacement.....	45
Midplane	45
Before you begin	45
Verifying component failure	45
Removing the midplane	46
Installing the midplane	51
Verifying component replacement.....	51
Backplane	51
Before you begin	51
Verifying component failure	52
Removing the backplane	52
Installing the backplane	57
Verifying component replacement.....	57
Updating firmware.....	58
Acronyms and abbreviations.....	59
Index.....	61

About this guide

This maintenance and service guide provides information to help you:

- Service the HP StorageWorks 70 Modular Smart Array Enclosure (MSA70)
- Troubleshoot the MSA70

About this guide topics include:

- Intended audience
- Prerequisites
- Document conventions and symbols
- HP technical support
- Subscription service
- HP websites
- Documentation feedback

Intended audience

This guide is intended for use by system administrators and technicians who are experienced with the following:

- SAN management
- Network administration
- Network installation

Prerequisites

Before servicing the MSA70, consider the following items:

- Knowledge of operating system
- Knowledge of related hardware/software
- Previous version of the product/firmware

Document conventions and symbols

Table 1 Document conventions

Convention	Element
Blue text: Table 1	Cross-reference links and e-mail addresses
Blue, underlined text: http://www.hp.com	website addresses
Bold text	<ul style="list-style-type: none">• Keys that are pressed• Text typed into a GUI element, such as a box• GUI elements that are clicked or selected, such as menu and list items, buttons, tabs, and check boxes

<i>Italic text</i>	Text emphasis
Monospace text	<ul style="list-style-type: none"> • File and directory names • System output • Code • Commands, their arguments, and argument values
<i>Monospace, italic text</i>	<ul style="list-style-type: none"> • Code variables • Command variables
Monospace, bold text	Emphasized monospace text

WARNING!

Indicates that failure to follow directions could result in bodily harm or death.

CAUTION:

Indicates that failure to follow directions could result in damage to equipment or data.

IMPORTANT:

Provides clarifying information or specific instructions.

NOTE:

Provides additional information.

TIP:

Provides helpful hints and shortcuts.

HP technical support

For worldwide technical support information, see the HP support website: <http://www.hp.com/support>.

Before contacting HP, collect the following information:

- Product model names and numbers
- Technical support registration number (if applicable)
- Product serial numbers
- Error messages
- Operating system type and revision level
- Detailed questions

For continuous quality improvement, calls may be recorded or monitored.

Product warranties

For information about HP StorageWorks product warranties, see the warranty information website: <http://www.hp.com/go/storagewarranty>.

Subscription service

HP recommends that you register your product at the Subscriber's Choice for Business website:
<http://www.hp.com/go/e-updates>.

After registering, you will receive e-mail notification of product enhancements, new driver versions, firmware updates, and other product resources.

HP websites

For additional information, see the following HP websites:

- <http://www.hp.com>
- <http://www.hp.com/go/storage>
- http://www.hp.com/service_locator
- <http://www.hp.com/support/manuals>
- <http://www.hp.com/support/downloads>

Documentation feedback

HP welcomes your feedback. To make comments and suggestions about product documentation, please send a message to storagedocs.feedback@hp.com. All submissions become the property of HP.

Illustrated parts catalog

System components

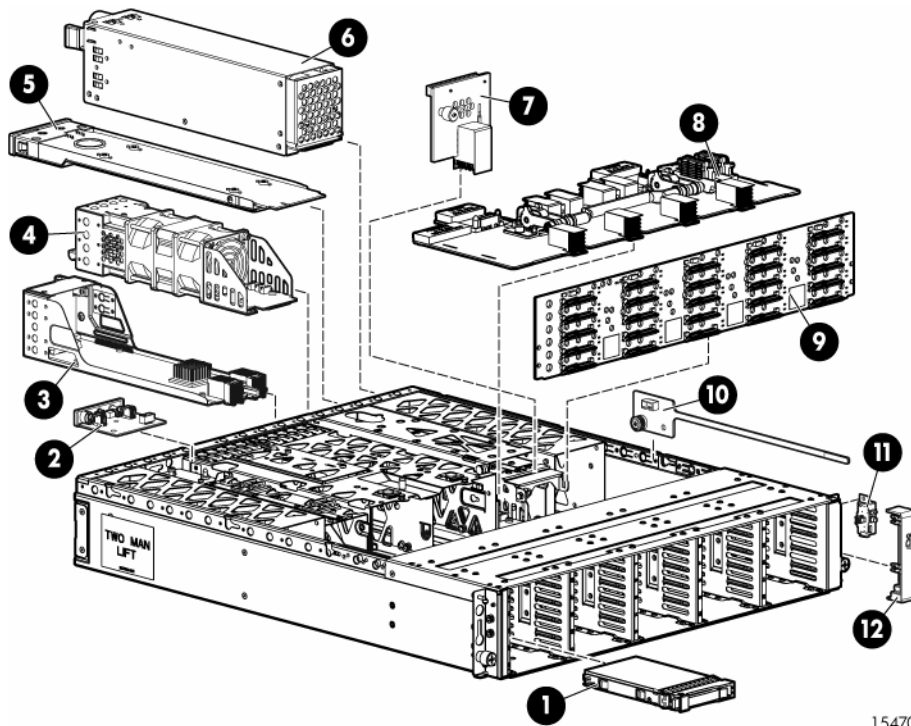

15470

Item	Description	Spare part number	Customer self repair (on page 19)
1	Hard drives	—	—
	a) 36-GB SAS, 10,000 rpm	376596-001	Mandatory ¹
	b) 36-GB SAS, 15,000 rpm *	432332-001	Mandatory ¹
	c) 72-GB SAS, 10,000 rpm *	447447-021	Mandatory ¹
	d) 72-GB SAS, 15,000 rpm *	418373-001	Mandatory ¹
	e) 146-GB SAS 10,000 rpm *	432320-001	Mandatory ¹
	f) 60-GB SATA, 5,400 rpm *	405419-001	Mandatory ¹
	g) 80-GB SATA, 5,400 rpm *	431907-00	Mandatory ¹
	h) 160-GB SATA, 5,400 rpm *	431909-00	Mandatory ¹
2	Power UID module	399054-001	Optional ²
3	I/O module	399049-001	Mandatory ¹
4	Fan module	399052-001	Mandatory ¹

Item	Description	Spare part number	Customer self repair (on page 19)
5	7-segment display board	399057-001	Optional ²
6	Power supply	405914-001	Mandatory ¹
7	Riser board	399056-001	Optional ²
8	Midplane	430148-001	Optional ²
9	Backplane	430149-001	Optional ²
10	Power on/off module	399055-001	Optional ²
11	Front UID module	399053-001	Optional ²
12	Plastic bezel	N/A	N/A

*Not shown ¹Mandatory—Parts for which customer self repair is mandatory. If you request HP to replace these parts, you will be charged for the travel and labor costs of this service. ²Optional—Parts for which customer self repair is optional. These parts are also designed for customer self repair. If, however, you require that HP replace them for you, there may or may not be additional charges, depending on the type of warranty service designated for your product.

Specifications

This chapter provides the environmental and enclosure specifications, and supported cable lengths for the MSA70.

Environmental specifications

Specification	Value
Temperature range	
Operating*	10°C to 35°C (50°F to 95°F) Maximum rate of change is 10° C/hr (50° F/hr)
Storage	-30°C to 60°C (-22°F to 140°F) Maximum rate of change is 20° C/hr (68° F/hr)
Relative humidity**	
Operating	10% to 90% relative humidity (Rh), 28° C (82.4° F) maximum wet bulb temperature, non-condensing
Storage	5% to 95% relative humidity (Rh), 38.7° C (101.66° F) maximum wet bulb temperature, non-condensing
Altitude ‡	
Operating	3048 m (10,000 ft) This value may be limited by the type and number of options installed.
Non-operating	9144 m (30, 000 ft)
*Temperature ratings shown are for sea level. An altitude derating of 1°C per 300 m (1.8°F per 1,000 ft) to 3048 m (10,000 ft) is applicable. No direct sunlight allowed. The upper limit may be limited by the type and number of options installed. ** Storage maximum humidity of 95% is based on a maximum temperature of 45°C (113°F). Altitude maximum for storage corresponds to a pressure minimum of 70 KPa. ‡ Maximum allowable altitude change rate is 457 m/min (1500 ft/min).	

Enclosure specifications

Specification	Value
Height	8.8 cm (3.47 in)
Depth	59 cm (23.25 in)
Width	44.80 cm (17.64 in)
Weight (maximum)	21.77 kg (48 lb)
Weight (no drives installed)	15.88 kg (35 lb)

Supported cables

A 0.5-m (1.64-ft) SAS cable ships standard with the enclosure. HP recommends using the shortest cable possible, however, other supported cable lengths between SAS ports are 2 m (6.56 ft), 4 m (13.12 ft), and 6 m (19.69 ft). To acquire different lengths, contact the nearest authorized HP reseller.

Identifying components

This chapter identifies the components of the MSA70 and identifies and describes the status LEDs of the system:

- Front panel components
- Front panel LEDs
- Rear panel components
- Rear panel LEDs and buttons
- Hard drive bay numbers
- Hard drive LEDs
- Hard drive LED combinations

Front panel components

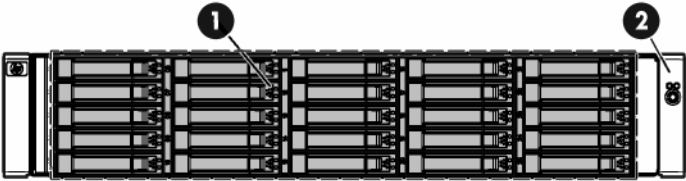

15486

Item	Description
1	Hard drive bays
2	Front unit ID (UID) module

Front panel LEDs

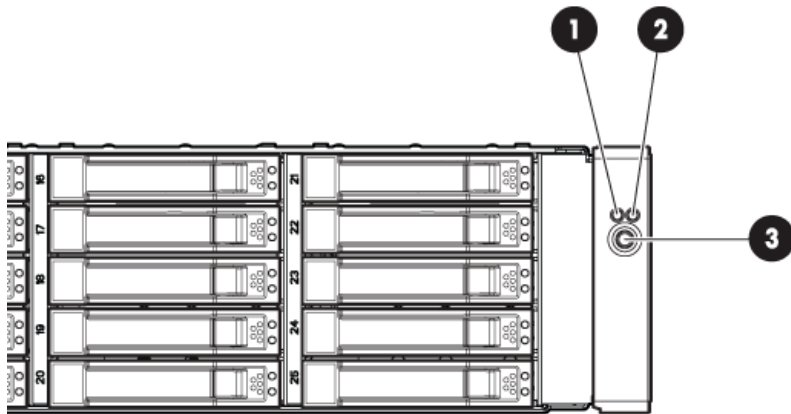

15460

Item	Description	Status
1	Heartbeat LED	Green = System activity Off = No system activity
2	Fault LED	Amber = Fault condition Off = No fault condition
3	UID button/LED	Blue = Identified Blue flashing = Active remote management Off = No active remote management

Rear panel components

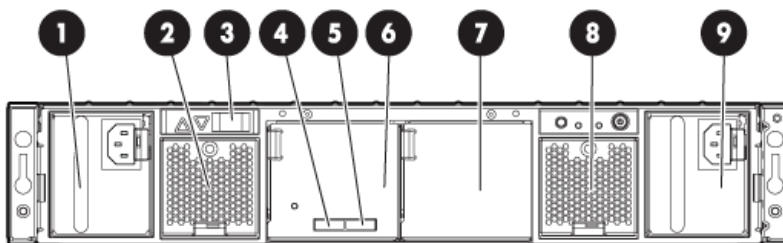

15461

Item	Description
1	Power supply 1

Item	Description
2	Fan 1
3	7-segment display board
4	SAS in connector ●
5	SAS out connector ◆
6	I/O module
7	For future use
8	Fan 2
9	Power supply 2

Rear panel LEDs and buttons

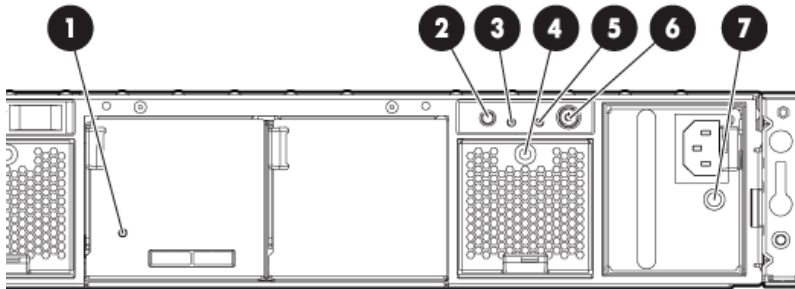

15462

Item	Description	Status
1	I/O module LED	Green = System activity Amber = Fault condition Off = No system activity
2	UID button/LED	Blue = Identified Blue flashing = Active remote management Off = No active remote management
3	Heartbeat LED	Green = System activity Off = No system activity
4	Fan LED	Green = Normal operation Amber = Fault condition Off = Fan unseated from connector or failed
5	System fault LED	Amber = Fault condition Off = No fault condition
6	Power On/Standby button/system power LED	Green = On Amber = Standby (auxiliary power present) Off = Off

Item	Description	Status
7	Power supply LED	<p>Green = Power turned on and power supply functioning properly</p> <p>Amber = Standby (auxiliary power present)</p> <p>Blinking amber = Power to this power supply not present</p> <p>Off = One or more of the following conditions exists:</p> <ul style="list-style-type: none"> • A/C power unavailable • Power supply failed • Power supply exceeded current limit

Hard drive bay numbers

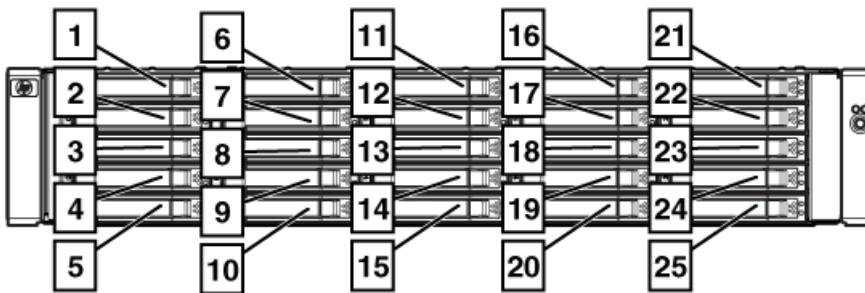

15463

Hard drive LEDs

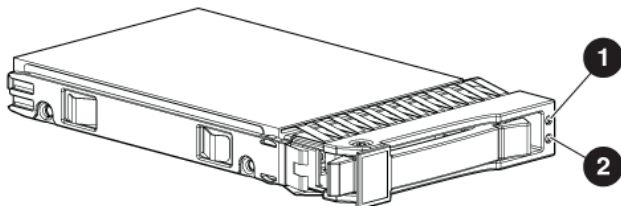

15464

Item	Description
1	Fault/UID LED (amber/blue)
2	Online/activity LED (green)

Hard drive LED combinations

NOTE:

Predictive failure alerts can occur only when the enclosure is connected to a Smart Array controller.

Online/activity LED (green)	Fault/UID LED (amber/blue)	Interpretation
On, off, or flashing	Alternating amber and blue	The drive has failed, or a predictive failure alert has been received for this drive; it also has been selected by a management application.
On, off, or flashing	Steadily blue	The drive is operating normally, and it has been selected by a management application.
On	Amber, flashing regularly (1 Hz)	A predictive failure alert has been received for this drive. Replace the drive as soon as possible.
On	Off	The drive is online, but it is not currently active.
Flashing regularly (1 Hz)	Amber, flashing regularly (1 Hz)	Do not remove the drive. Removing a drive may terminate the current operation and cause data loss. The drive is part of an array that is undergoing capacity expansion or a stripe size migration, but a predictive failure alert has been received for this drive. To minimize the risk of data loss, do not replace the drive until the expansion or migration is complete.
Flashing regularly (1 Hz)	Off	Do not remove the drive. Removing a drive may terminate the current operation and cause data loss. The drive is rebuilding, or it is part of an array that is undergoing capacity expansion or a stripe size migration.
Flashing irregularly	Amber, flashing regularly (1 Hz)	The drive is active, but a predictive failure alert has been received for this drive. Replace the drive as soon as possible.
Flashing irregularly	Off	The drive is active and it is operating normally.
Off	Steadily amber	A critical fault condition has been identified for this drive and the controller has placed it offline. Replace the drive as soon as possible.
Off	Amber, flashing regularly (1 Hz)	A predictive failure alert has been received for this drive. Replace the drive as soon as possible.
Off	Off	The drive is offline, a spare, or not configured as part of an array.

Diagnostic tools

This chapter describes the diagnostic tools available for the MSA70.

Integrated Management Log

The Integrated Management Log (IML) records events and stores them in an easy-to-view form. The IML timestamps each event with 1-minute granularity.

You can view recorded events in the IML in several ways, including the following:

- From within HP SIM
- From within Survey Utility
- From within operating system-specific IML viewers
 - For NetWare: IML Viewer
 - For Windows: IML Viewer
 - For Linux: IML Viewer Application
- From within the iLO user interface
- From within HP Insight Diagnostics

For more information, see the Management CD in the HP ProLiant Essentials Foundation Pack.

Array Diagnostic Utility

The Array Diagnostic Utility (ADU) collects information about array controllers and generates a list of detected problems. ADU can be accessed from the SmartStart CD or downloaded from the HP website: <http://www.hp.com>.

Customer replaceable components

This chapter includes the following information regarding the removal and replacement of MSA70 components:

- Overview of removal and replacement procedures
- Description of Customer Self Repair
- Description of all warnings and precautions to consider when removing and replacing components of the MSA70

IMPORTANT:

To reduce the risk of personal injury or damage to the equipment, observe all warnings and cautions throughout this chapter.

Overview of removal and replacement procedures

To help you successfully replace hardware components in your enclosure, the following information is included in the component replacement procedures:

- **Before you begin** — This section may be included in the procedures to include component-specific precautions or notices. Be sure to read and observe these statements.
- **Verifying component failure** — Before replacing a component, confer with HP technical support to verify that the hardware component has failed and that you are authorized to replace it yourself.

Verification procedures may include:

- Viewing status messages sent to the enclosure LCD panels (front and rear).
- Viewing the LED illumination patterns on the enclosure and the component.
- Viewing system event logs or other reports generated by systems management tools, such as HP Systems Insight Manager (HP SIM) or WEBES.
- **Removing the failed component** — The procedural steps to properly remove the component, including illustrations.
- **Installing the component** — The procedural steps to properly install the component, including illustrations.
- **Verifying component replacement** — After replacing the component, make sure to verify that the replacement component is operating properly.

Verification procedures may include:

- Viewing status messages sent to the enclosure LCD panels (front and rear).
- Viewing the LED illumination patterns on the enclosure and the component.
- Viewing system event logs or other reports generated by systems management tools, such as HP Systems Insight Manager or WEBES.

Customer self repair

HP products are designed with many Customer Self Repair (CSR) parts to minimize repair time and allow for greater flexibility in performing defective parts replacement. If during the diagnosis period HP (or HP

service providers or service partners) identifies that the repair can be accomplished by the use of a CSR part, HP will ship that part directly to you for replacement. There are two categories of CSR parts:

- **Mandatory**—Parts for which customer self repair is mandatory. If you request HP to replace these parts, you will be charged for the travel and labor costs of this service.
- **Optional**—Parts for which customer self repair is optional. These parts are also designed for customer self repair. If, however, you require that HP replace them for you, there may or may not be additional charges, depending on the type of warranty service designated for your product.

NOTE: Some HP parts are not designed for customer self repair. In order to satisfy the customer warranty, HP requires that an authorized service provider replace the part. These parts are identified as “No” in the Illustrated Parts Catalog.

Based on availability and where geography permits, standard HP CSR part delivery is next business day. Same business day deliver options may be discussed with your support specialist.

Replacement instructions are included in this document, in the spare kits, and on the HP website. If further assistance is required, you can call the HP Technical Support Center and a support specialist will help you over the phone.

In the materials shipped with a CSR component, HP specifies whether the defective component must be returned to HP. In cases where it is required, you must ship the defective part back to HP within a defined period of time, normally five business days. The defective part must be returned with the associated documentation in the provided shipping material. Failure to return the defective part may result in HP billing you for the replacement. With a CSR, HP will pay all shipping and part return costs and determine the courier/carrier to be used.

For more information about HP’s Customer Self Repair program, contact your local service provider. For the North American program, see the HP website: <http://www.hp.com/go/selfrepair>.

CSR is available for most HP products currently under warranty. For more information on warranty service, see the HP website: <http://h18006.www1.hp.com/products/storageworks/warranty.html>.

Parts only warranty service

Your HP Limited Warranty may include a parts only warranty service. Under the terms of parts only warranty service, HP will provide replacement parts free of charge.

For parts only warranty service, CSR part replacement is mandatory. If you request HP to replace these parts, you will be charged for the travel and labor costs of this service.

Procuring the spare component

The [Illustrated parts catalog](#) lists the parts that qualify for CSR, including assembly and spare numbers. Parts have a nine-character component number on their label. The first six characters identify the element; the last three characters define the revision level. The replacement component revision level must be the same as, or later than the number on the failed component. The greater the revision level, the later the revision.

Returning the defective component

In the materials shipped with a CSR component, HP specifies whether the defective component must be returned to HP. In cases where it is required, you must ship the defective part back to HP within a defined period of time, normally five business days. The defective part must be returned with the associated documentation in the provided shipping material. Failure to return the defective part may result in HP billing you for the replacement. With a CSR, HP will pay all shipping and part return costs and determine the courier/carrier to be used.

Recommended tools

When replacing certain components, such as the power on/off module, the following tools may be necessary:

- Torx T-10 and Torx T-15 screwdrivers
- Phillips screwdriver

Warnings and precautions

Electrostatic discharge information

To prevent damage to the system, be aware of the precautions you need to follow when setting up the system or handling parts. A discharge of static electricity from a finger or other conductor may damage system boards or other static-sensitive devices. This type of damage may reduce the life expectancy of the device.

To prevent electrostatic damage, observe the following precautions:

- Avoid hand contact by transporting products in static-safe containers such as conductive tubes, bags, or boxes.
- Keep electrostatic-sensitive parts in their containers until they arrive at static-free stations.
- Cover workstations with approved static-dissipating material. Provide a wrist strap connected to the work surface and properly grounded (earthed) tools and equipment.
- Keep work area free of nonconducting materials such as ordinary plastic assembly aids and foam packing.
- Place parts on a grounded surface before removing them from their containers.
- Avoid touching pins, leads, or circuitry.
- Always make sure you are properly grounded when touching a static-sensitive component or assembly.
- Always place hard drives with the Printed Circuit Board (PCB) side down.
- Use conductive field service tools.

Grounding methods

There are several methods for grounding. Use one or more of the following methods when handling or installing electrostatic-sensitive parts:

- Use a wrist strap connected by a ground cord to a grounded workstation or computer chassis. Wrist straps are flexible straps with a minimum of 1 megohm $\pm 10\%$ resistance in the ground cords. To provide proper ground, wear the strap snug against the skin.
- Use heel straps, toe straps, or boot straps at standing workstations. Wear the straps on both feet when standing on conductive floors or dissipating floor mats.
- Use conductive field service tools.
- Use a portable field service kit with a folding static-dissipating work mat.

If you do not have any of the suggested equipment for proper grounding, have an Authorized HP Reseller install the part.

NOTE:

For more information on static electricity or assistance with product installation, contact your HP Authorized Reseller.

Equipment symbols

These symbols may be located on equipment in areas where hazardous conditions may exist.

WARNING!

Any enclosed surface or area of the equipment marked with these symbols indicates the presence of electrical shock hazards. Enclosed area contains no operator serviceable parts. To reduce the risk of injury from electrical shock hazards, do not open this enclosure.

WARNING!

Any RJ-45 receptacle marked with these symbols indicates a network interface connection. To reduce the risk of electrical shock, fire, or damage to the equipment, do not plug telephone or telecommunications connectors into

WARNING!

Any surface or area of the equipment marked with these symbols indicates the presence of a hot surface or hot component. Contact with this surface could result in injury.

WARNING!

Power supplies or systems marked with these symbols indicate the presence of multiple sources of power.

WARNING!

Any product or assembly marked with these symbols indicates that the component exceeds the recommended weight for one individual to handle safely.

Weight warning

WARNING!

Components can be very heavy. To reduce the risk of personal injury or damage to the equipment:

- Remove all pluggable power supplies and modules to reduce the weight of the product before lifting it.
- Observe local occupational health and safety requirements and guidelines for manual material handling.
- Get help to lift and stabilize the product during installation or removal, especially when the product is not fastened to the rails. When the component weighs more than 22.5 kg (50 lb), at least two people must lift the component into the rack together. If the component is loaded into the rack above chest level, a third person must assist in aligning the rails while the other two support the component.
- Use caution when installing the component in or removing the component from the rack; it is unstable when not fastened to the rails.

Rack warnings and precautions

Ensure that precautions have been taken to provide for rack stability and safety. It is important to follow these precautions providing for rack stability and safety, and to protect both personnel and property.

Heed all cautions and warnings that may be included in the installation instructions.

WARNING!

Verify that the AC power supply branch circuit that provides power to the rack is not overloaded. Overloading AC power to the rack power supply circuit increases the risk of personal injury, fire, or damage to the equipment. The total rack load should not exceed 80 percent of the branch circuit rating. Consult the electrical authority having jurisdiction over your facility wiring and installation requirements.

WARNING!

To reduce the risk of personal injury or damage to the equipment:

- Observe local occupational safety requirements and guidelines for heavy equipment handling.
- Obtain adequate assistance to lift and stabilize the product during installation or removal.
- Remove all pluggable power supplies and modules to reduce the weight of the product.
- Always load the heaviest item first, and load the rack from the bottom up. This makes the rack “bottom-heavy” and helps prevent the rack from becoming unstable.
- Extend the leveling jacks to the floor.
- Rest the full weight of the rack on the leveling jacks.
- Attach the stabilizing feet to the rack if it is a single-rack installation.
- Ensure the racks are coupled in multiple-rack installations.
- Fully extend the bottom stabilizers on the equipment. Ensure that the equipment is properly supported/braced when installing options and boards.
- Be careful when sliding rack components with slide rails into the rack. The slide rails could pinch your fingertips.
- Ensure that the rack is adequately stabilized before extending a rack component with slide rails outside the rack. Extend only one component at a time. A rack may become unstable if more than one component is extended for any reason.
- Do not attempt to move a fully loaded equipment rack. Remove equipment from the rack before moving the rack.
- At least two people are needed to safely unload the rack from the pallet. An empty 42U rack weighs 115 kg (253 lb), is over 2.1 meters (7 ft) tall, and can become unstable when being moved on its casters.

Do not stand in front of the rack as it rolls down the ramp from the pallet; handle it from the sides.

Stabilize the device by keeping the unit on the rails.

Device warnings and precautions

CAUTION:

System power to the MSA70 does not shut off completely with the power supply buttons. The LCD indicators on the front panel power buttons should be considered as on and standby, rather than on and off. The standby position removes power from most of the electronics and the hard drives, but portions of the power supplies and some internal circuitry remain active.

- To remove all power from the system, you must disconnect the power cord from the enclosure.
- In systems with multiple power supplies, you must disconnect all the power cords to remove power completely from the enclosure.

WARNING!

To reduce the risk of personal injury or damage to the equipment, observe local occupational health and safety requirements and guidelines for manually handling material.

WARNING!

To reduce the risk of personal injury or damage to the equipment, the installation of non-hot-pluggable components should be performed only by individuals who are qualified in servicing computer equipment, knowledgeable about the procedures and precautions, and trained to deal with products capable of producing hazardous energy levels.

CAUTION:

Before replacing a hot-pluggable component, ensure that steps have been taken to prevent loss of data.

WARNING!

To reduce the risk of electric shock or damage to the equipment:

- Allow the product to cool before removing covers and touching internal components.
- Do not disable the power cord grounding plug. The grounding plug is an important safety feature.
- Plug the power cord into a grounded (earthed) electrical outlet that is easily accessible at all times.
- Disconnect power from the device by unplugging the power cord from either the electrical outlet or the device.
- Do not use conductive tools that could bridge live parts.
- Remove all watches, rings, or loose jewelry when working in hot-plug areas of an energized device.
- Install the device in a controlled access location where only qualified personnel have access to the device.
- Power down the equipment and disconnect power to all AC power cords before removing any access covers for non-hot-pluggable areas.
- Do not replace non-hot-pluggable components while power is applied to the product. Power down the device and then disconnect all AC power cords.
- Do not exceed the level of repair specified in the procedures in the product documentation. All troubleshooting and repair procedures are detailed to allow only subassembly or module-level repair. Because of the complexity of the individual boards and subassemblies, do not attempt to make repairs at the component level or to make modifications to any printed wiring board. Improper repairs can create a safety hazard.

CAUTION:

Protect the installed solution from power fluctuations and temporary interruptions with a regulating Uninterruptible Power Supply (UPS). This device protects the hardware from damage caused by power surges and voltage spikes, and keeps the system in operation during a power failure.

CAUTION:

To properly ventilate the system, you must provide at least 7.6 cm (3.0 in.) of clearance at the front and back of the device.

Removal and replacement procedures

This chapter describes how to power up and power down the MSA70, and how to remove and replace the following MSA70 components:

- Access panel
- Hard drive blank
- Hot-plug SAS or SATA hard drive
- Hot-plug power supply
- Hot-plug fan
- I/O module
- Front UID module
- Power on/off module
- Power UID module
- 7-segment display board
- Riser board
- Midplane
- Backplane

Powering up and powering down

CAUTION:

Be sure that the server to which the MSA70 is connected is the first unit to be powered down and the last to be powered back up. Taking this precaution ensures that the system does not erroneously mark the drives as failed when the server is powered up.

IMPORTANT:

If installing a hot-plug device, it is not necessary to power down the enclosure.

Powering up

Observe the following guidelines before powering up the enclosure:

- Install all components of the enclosure.
- Install hard drives in the enclosure so the connected host controller can identify and configure them at powerup.
- Always power up the enclosure first, and then the server. This ensures that the servers, during their discovery, see the enclosure as an operational device. If you do not power up the enclosure before powering up the servers, you will need to power down the servers, ensure that the enclosure is powered up, and then power back up the servers.

To power up the enclosure:

1. Complete server hardware installation and cabling. See the server documentation.
2. Connect the SAS cables and power cords to the enclosure.
3. Press and hold the Power On/Standby button on the enclosure. Wait and observe the system power LED and fan modules. When the enclosure powers up, the system power LED illuminates solid green and the fans spin to a high speed, and then spin down to a low speed.
4. Power up the servers. See the server documentation.

Powering down

To power down the enclosure:

1. Power down any attached servers. See the server documentation.
2. Press the Power On/Standby button on the enclosure.
3. Wait for the system power LED to go from green to amber.
4. Disconnect the power cords.

The system is now without power.

Access panel

Removing the access panel

1. Power down the enclosure:
 - a. Power down any attached servers. See the server documentation.
 - b. Press the Power On/Standby button on the enclosure.
 - c. Wait for the system power LED to go from green to amber.
 - d. Disconnect the power cords.
2. Extend or remove the enclosure from the rack in which it may be installed:
 - a. Loosen the front panel thumbscrews that secure the enclosure faceplate to the front of the rack.
 - b. Disconnect the cabling and extend or remove the enclosure from the rack.
3. Lift the access panel latch on top of the enclosure (1) and slide the access panel to the rear (2).

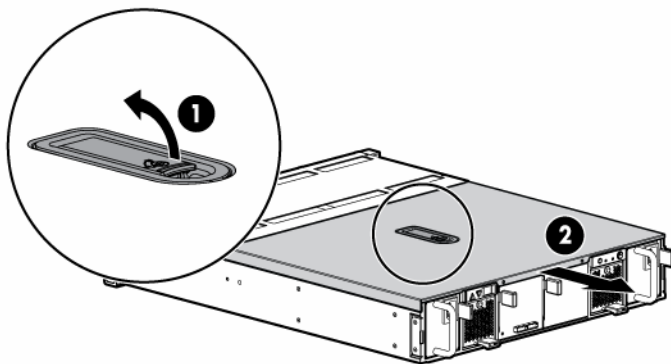

15484

4. Remove the access panel.

WARNING!

To reduce the risk of personal injury from hot surfaces, allow the drives and the internal system components to cool before touching them.

CAUTION:

To prevent damage to electrical components, properly ground the enclosure before beginning any installation procedure. Improper grounding can cause ESD.

Installing the access panel

To install the access panel, reverse the removal procedure:

1. Slide the access panel into place on the chassis.
2. Press down the access panel latch on top of the enclosure to secure the panel.

Hard drive blank

CAUTION:

To prevent improper cooling and thermal damage, do not operate the enclosure unless all bays are populated with either a component or a blank.

Removing the hard drive blank

1. Press in the release latches (1).
2. Pull the hard drive blank out of the bay (2).

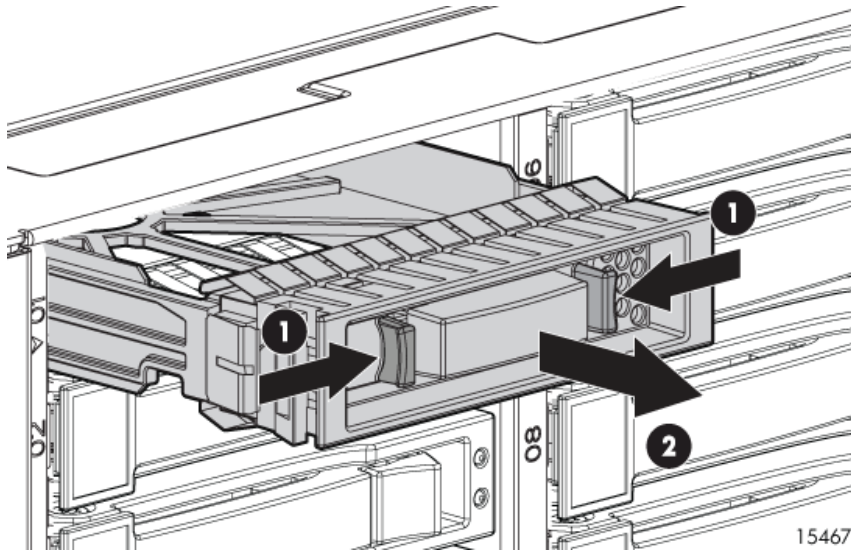

Installing the hard drive blank

To install the blank, slide the blank into the bay until it locks into place.

Hot-plug hard drive

Before you begin

CAUTION:

- Before removing the failed component, make sure that you have the replacement part available. Removing a component impacts the airflow and cooling ability of the device.
- Do not remove more than one component or blank from the enclosure at a time. Doing so impacts the airflow and cooling ability of the device. To avoid possible overheating, insert the new or replacement component as quickly as possible. If the internal temperature exceeds acceptable limits, the MSA70 may overheat and automatically shut down or restart.
- Parts can be damaged by electrostatic discharge. Use proper anti-static protection.

Verifying component failure

Use the following methods to verify component failure:

- Check the host log or run an ADU report for hard drive errors.
- Check the hard drive status LEDs as identified in the following table:

Online/activity LED (green)	Fault/UID LED (amber/blue)	Interpretation
On, off, or flashing	Alternating amber and blue	The drive has failed, or a predictive failure alert has been received for this drive; it also has been selected by a management application.
On, off, or flashing	Steadily blue	The drive is operating normally, and it has been selected by a management application.
On	Amber, flashing regularly (1 Hz)	A predictive failure alert has been received for this drive. Replace the drive as soon as possible.
On	Off	The drive is online, but it is not currently active.
Flashing regularly (1 Hz)	Amber, flashing regularly (1 Hz)	Do not remove the drive. Removing a drive may terminate the current operation and cause data loss. The drive is part of an array that is undergoing capacity expansion or a stripe size migration, but a predictive failure alert has been received for this drive. To minimize the risk of data loss, do not replace the drive until the expansion or migration is complete.
Flashing regularly (1 Hz)	Off	Do not remove the drive. Removing a drive may terminate the current operation and cause data loss. The drive is rebuilding, or it is part of an array that is undergoing capacity expansion or a stripe size migration.
Flashing irregularly	Amber, flashing regularly (1 Hz)	The drive is active, but a predictive failure alert has been received for this drive. Replace the drive as soon as possible.
Flashing irregularly	Off	The drive is active and it is operating normally.
Off	Steadily amber	A critical fault condition has been identified for this drive and the controller has placed it offline. Replace the drive as soon as possible.
Off	Amber, flashing regularly (1 Hz)	A predictive failure alert has been received for this drive. Replace the drive as soon as possible.

Online/activity LED (green)	Fault/UID LED (amber/blue)	Interpretation
Off	Off	The drive is offline, a spare, or not configured as part of an array.

You can replace hard drives without powering down the system. However, before replacing a degraded drive:

- Open HP SIM and inspect the Error Counter window for each physical drive in the same array to confirm that no other drives have any errors. (For details, see the HP SIM documentation on the Management CD located on the HP ProLiant Essentials Foundation Pack.)
- Be sure that the array has a current, valid backup.
- Use replacement drives that have a capacity at least as great as that of the smallest drive in the array. The controller immediately fails drives that have insufficient capacity.

To minimize the likelihood of fatal system errors, take these precautions when removing failed drives:

- Do not remove a degraded drive if any other drive in the array is offline (the online LED is off). In this situation, no other drive in the array can be removed without data loss.

Exceptions:

- When RAID 1+0 is used, drives are mirrored in pairs. Several drives can be in a failed condition simultaneously (and they can all be replaced simultaneously) without data loss, as long as no two failed drives belong to the same mirrored pair.
- When RAID 6 with ADG is used, two drives can fail simultaneously (and be replaced simultaneously) without data loss.
- If the offline drive is a spare, the degraded drive can be replaced.
- Do not remove a second drive from an array until the first failed or missing drive has been replaced *and* the rebuild process is complete. (The rebuild is complete when the online LED on the front of the drive stops blinking.)

Exceptions:

- In RAID 6 with ADG configurations, any two drives in the array can be replaced simultaneously.
- In RAID 1+0 configurations, any drives that are not mirrored to other removed or failed drives can be simultaneously replaced offline without data loss.

Removing the hard drive

1. Back up all data on the hard drive. Make sure that you read the information regarding hard drive replacement in [Verifying component failure](#) in this section.

2. Press the latch and slide it to the right to disengage the lever (1), and then open the lever (2).
3. Pull the hard drive out of the bay.

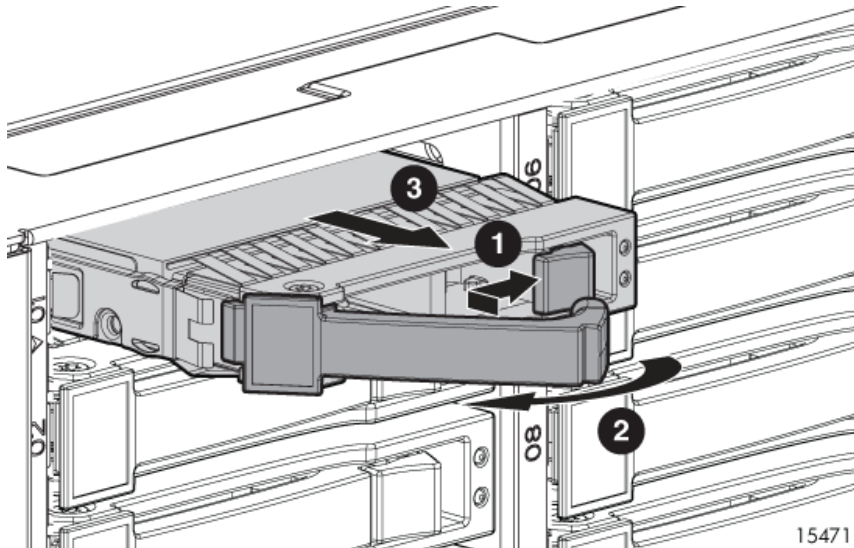

Installing the hard drive

To install the hard drive, reverse the removal procedure:

1. Slide the drive into the bay until it clicks, locking the drive into place.
2. Close the lever, making sure that it is flush with the front of the drive.

IMPORTANT:

When the drive is inserted, the drive LEDs flash for 2 seconds to indicate that the drive is seated properly and receiving power.

3. As the drive begins to spin, be sure that the drive LEDs illuminate one at a time and then turn off together to indicate that the system has recognized the new drive.

In fault-tolerant configurations, allow the replacement drive to be reconstructed automatically with data from the other drives. While reconstruction is in progress, the online LED flashes.

Verifying component replacement

After replacing the hard drive, check the hard drive status LEDs to be sure the drive is operating normally.

Hot-plug power supply

Before you begin

CAUTION:

- Before removing the failed component, make sure that you have the replacement part available. Removing a component impacts the airflow and cooling ability of the device.
- Do not remove more than one component or blank from the enclosure at a time. Doing so impacts the airflow and cooling ability of the device. To avoid possible overheating, insert the new or replacement component as quickly as possible. If the internal temperature exceeds acceptable limits, the MSA70 may overheat and automatically shut down or restart.

- Parts can be damaged by electrostatic discharge. Use proper anti-static protection.

Verifying component failure

Use the following methods to verify component failure:

- Check the hot-plug power supply status LED:

Green = Power turned on and power supply functioning properly

Amber = Standby (auxiliary power present)

Blinking amber = Power to this power supply not present

Off = One or more of the following conditions exists:

- A/C power unavailable
 - Power supply failed
 - Power supply exceeded current limit
- Check the host log for errors.

Removing the power supply

1. Disconnect the power cord from the power supply.
2. Press the latch inward (1) and pull the power supply out of the chassis (2).

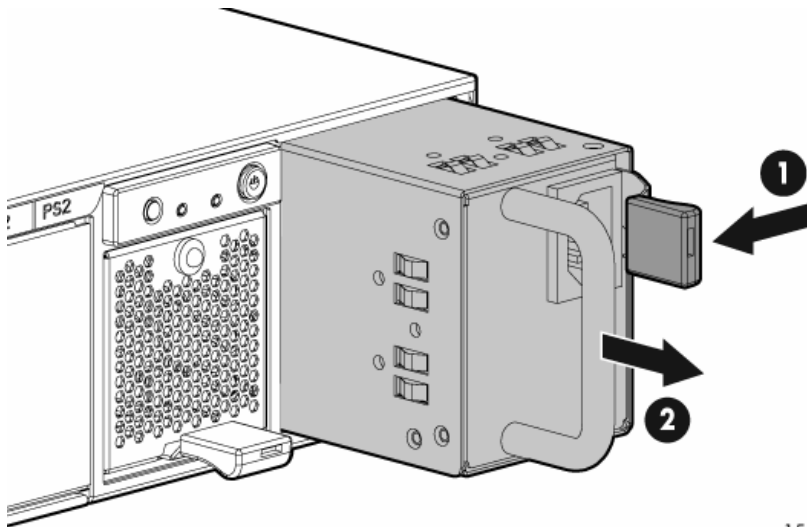

15473

Installing the power supply

To install the power supply, slide it into the chassis until it clicks into place.

Verifying component replacement

After replacing the power supply, check the power supply status LED.

Hot-plug fan

Before you begin

CAUTION:

- Before removing the failed component, make sure that you have the replacement part available. Removing a component impacts the airflow and cooling ability of the device.
- Do not remove more than one component or blank from the enclosure at a time. Doing so impacts the airflow and cooling ability of the device. To avoid possible overheating, insert the new or replacement component as quickly as possible. If the internal temperature exceeds acceptable limits, the MSA70 may overheat and automatically shut down or restart.
- Parts can be damaged by electrostatic discharge. Use proper anti-static protection.

Verifying component failure

Use the following methods to verify component failure:

- Check the fan status LED:
 - Green** = Normal operation
 - Amber** = Fault condition
 - Off** = Fan unseated from connector or failed
- Check the host log for errors.

Removing the fan

1. Press up on the release latch (1).
2. Slide the fan out of the chassis (2).

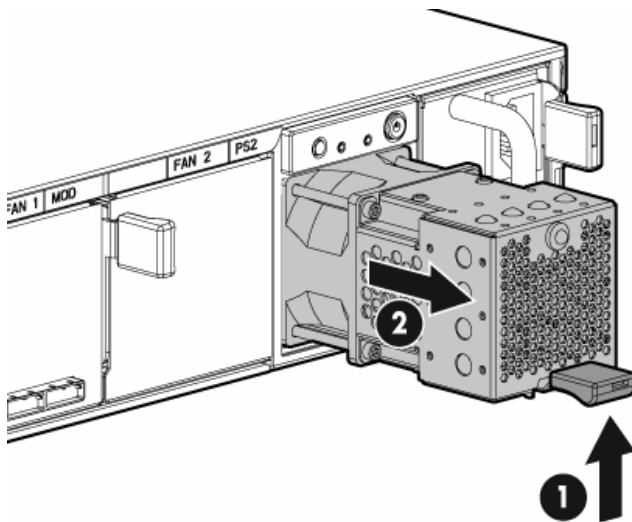

15474

Installing the fan

To install the fan, slide the fan into the chassis until it clicks into place.

Verifying component replacement

After replacing the fan, check the fan status LED.

I/O module

Before you begin

CAUTION:

- Before removing the failed component, make sure that you have the replacement part available. Removing a component impacts the airflow and cooling ability of the device.
- Do not remove more than one component or blank from the enclosure at a time. Doing so impacts the airflow and cooling ability of the device. To avoid possible overheating, insert the new or replacement component as quickly as possible. If the internal temperature exceeds acceptable limits, the MSA70 may overheat and automatically shut down or restart.
- Parts can be damaged by electrostatic discharge. Use proper anti-static protection.

Verifying component failure

Use the following methods to verify component failure:

- Check the I/O status LED:
 - Green** = System activity
 - Amber** = Fault condition
 - Off** = No system activity
- Check the host log for errors.

Removing the I/O module

1. Power down the enclosure:
 - a. Power down any attached servers. See the server documentation.
 - b. Press the Power On/Standby button on the enclosure.
 - c. Wait for the system power LED to go from green to amber.
 - d. Disconnect the power cords.
2. Disconnect any SAS cables connected to the I/O module.

3. Squeeze the lever (1) and pull it down (2).
4. Slide the I/O module out of the chassis (3).

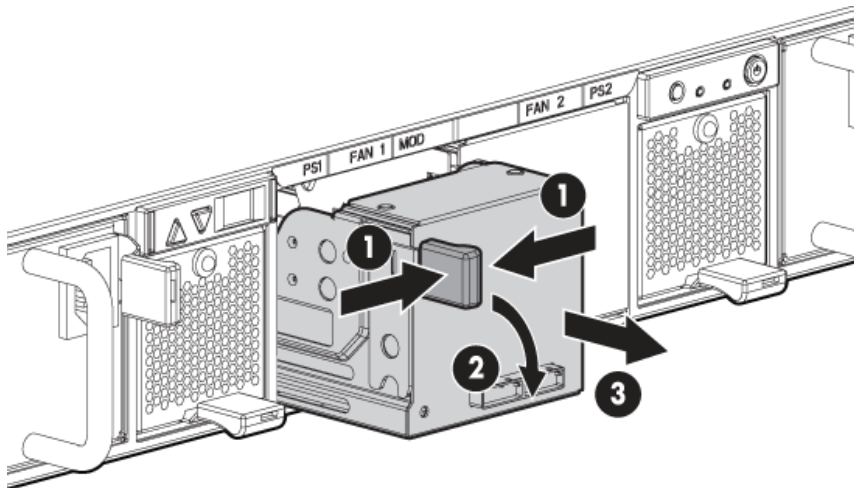

15475

Installing the I/O module

To install the I/O module:

1. Squeeze the lever and pull it down.
2. Slide the I/O module into the chassis until it clicks into place.
3. Connect SAS cables to the module.
4. Power up the enclosure.

Verifying component replacement

After replacing the I/O module, check the I/O module status LED.

Front UID module

Before you begin

CAUTION:

- Before removing the failed component, make sure that you have the replacement part available. Removing a component impacts the airflow and cooling ability of the device.
- Do not remove more than one component or blank from the enclosure at a time. Doing so impacts the airflow and cooling ability of the device. To avoid possible overheating, insert the new or replacement component as quickly as possible. If the internal temperature exceeds acceptable limits, the MSA70 may overheat and automatically shut down or restart.
- Parts can be damaged by electrostatic discharge. Use proper anti-static protection.

Verifying component failure

Use the following methods to verify component failure:

- Check the front UID module status LED:

Blue = Identified

Blue flashing = Active remote management

Off = No active remote management

- Check the host log for errors.

Removing the front UID module

1. Power down the enclosure:
 - a. Power down any attached servers. See the server documentation.
 - b. Press the Power On/Standby button on the enclosure.
 - c. Wait for the system power LED to go from green to amber.
 - d. Disconnect the power cords.
2. Remove the plastic bezel (1).
3. Remove the T-10 screw to release the module from the chassis (2).
4. Remove the front UID module (3).

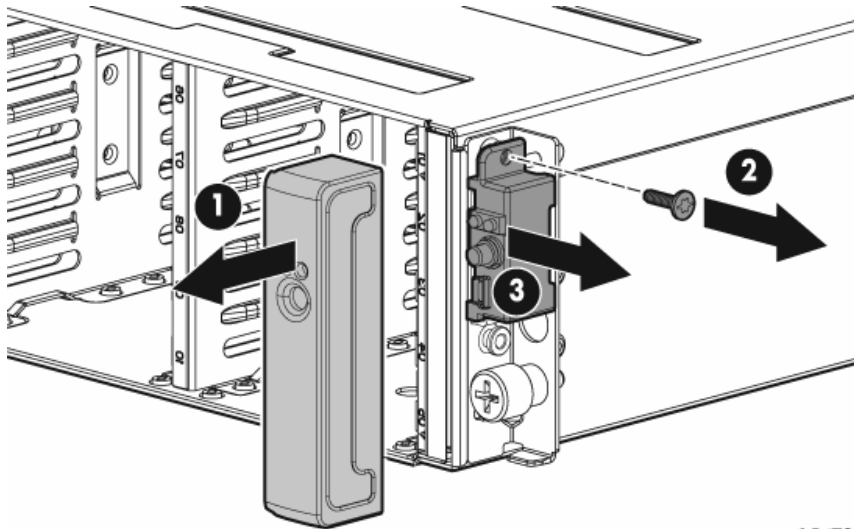

15472

Installing the front UID module

To install the front UID module, reverse the removal procedure:

1. Attach the module to the chassis, securing it with a T-10 screw.
2. Install the plastic bezel.
3. Power up the enclosure.

Verifying component replacement

After replacing the front UID module, check the front UID module status LED.

Power on/off module

Before you begin

CAUTION:

- Before removing the failed component, make sure that you have the replacement part available. Removing a component impacts the airflow and cooling ability of the device.
- Do not remove more than one component or blank from the enclosure at a time. Doing so impacts the airflow and cooling ability of the device. To avoid possible overheating, insert the new or replacement component as quickly as possible. If the internal temperature exceeds acceptable limits, the MSA70 may overheat and automatically shut down or restart.
- Parts can be damaged by electrostatic discharge. Use proper anti-static protection.

Verifying component failure

Use the following methods to verify component failure:

- Check the host log for errors.
- Check the heartbeat, fault, and power supply status LEDs as identified in the following table:

Item	Description
Heartbeat LED	Green = System activity Off = No system activity
Fault LED	Amber = Fault condition Off = No fault condition
Power supply LED	Green = Power turned on and power supply functioning properly Amber = Standby (auxiliary power present) Blinking amber = Power to this power supply not present Off = One or more of the following conditions exists: <ul style="list-style-type: none">• A/C power unavailable• Power supply failed• Power supply in standby mode• Power supply exceeded current limit

Removing the power on/off module

1. Power down the enclosure:
 - e. Power down any attached servers. See the server documentation.
 - f. Press the Power On/Standby button on the enclosure.
 - g. Wait for the system power LED to go from green to amber.
 - h. Disconnect the power cords.
2. Extend or remove the enclosure from the rack in which it may be installed:

- a. Loosen the front panel thumbscrews that secure the enclosure faceplate to the front of the rack.
 - b. Disconnect the cabling and extend or remove the enclosure from the rack.
3. Remove the access panel:
- c. Lift the access panel latch (1).
 - d. Slide the access panel to the rear (2).

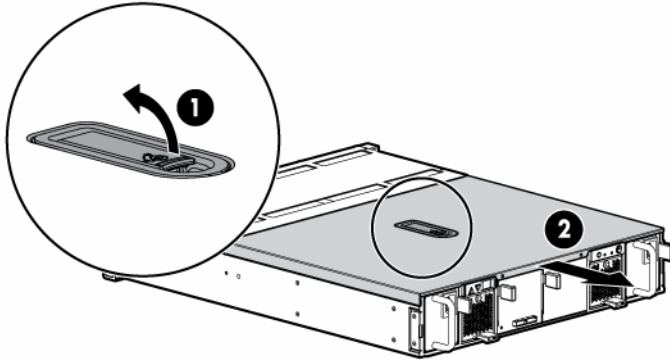

15484

4. Remove the front UID module:
- a. Remove the plastic bezel (1).
 - b. Remove the T-10 screw to release the module from the chassis (2).
 - c. Remove the module (3).

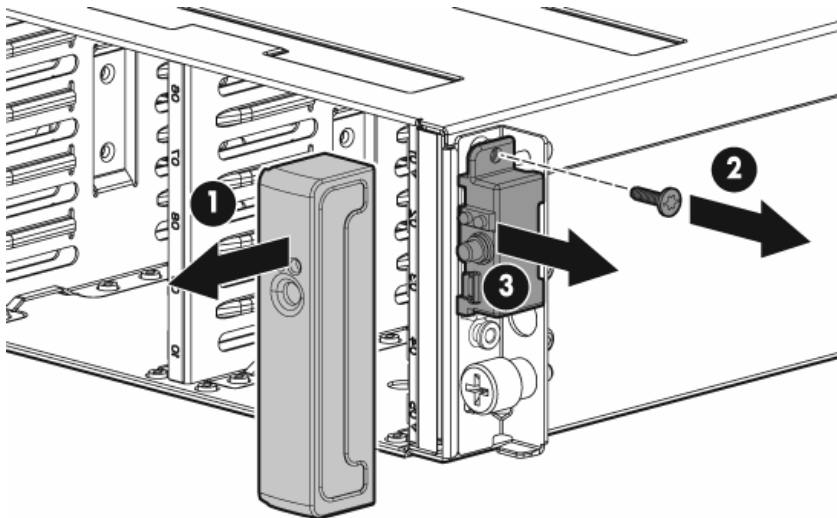

15472

5. Remove the power supply:
- a. Disconnect the power cord from the power supply.
 - b. Press the lever inward (1) and pull the power supply out of the chassis (2).

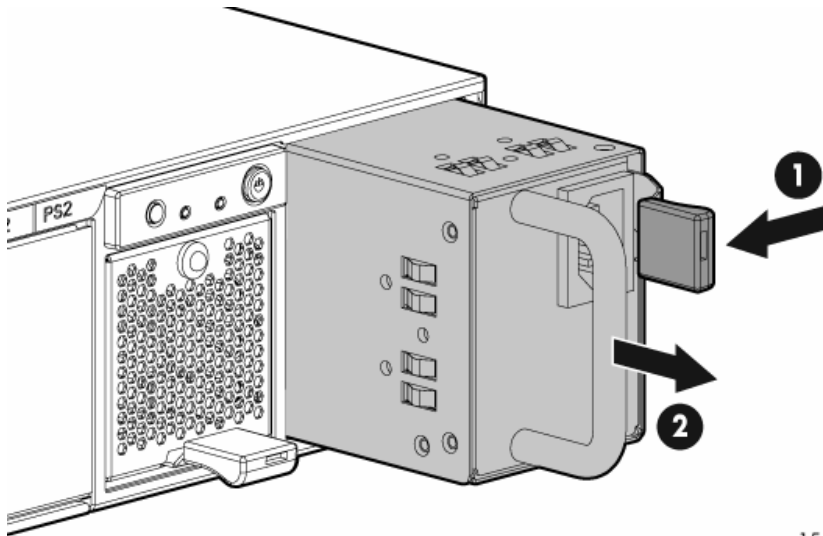

15473

6. Disconnect the cable from the power on/off module (1).
7. Loosen the thumbscrew on the module (2).
8. Slide the module back to remove it from the guide, and then lift it out of the chassis (3).

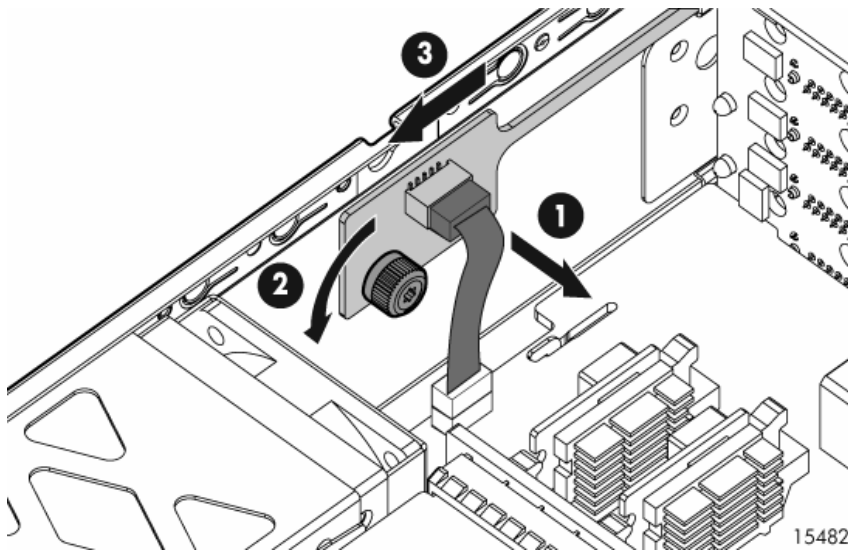

15482

Installing the power on/off module

To install the power on/off module, reverse the removal procedure:

1. Slide the module into the chassis using the guide and tighten the thumbscrew.
2. Connect the cable to the module.
3. Install the power supply and the front UID module.
4. Insert the enclosure into the rack and power up the enclosure.

Verifying component replacement

After replacing the power on/off module, check the heartbeat, fault, and power supply status LEDs to verify the module is operating normally.

Power UID module

Before you begin

CAUTION:

- Before removing the failed component, make sure that you have the replacement part available. Removing a component impacts the airflow and cooling ability of the device.
- Do not remove more than one component or blank from the enclosure at a time. Doing so impacts the airflow and cooling ability of the device. To avoid possible overheating, insert the new or replacement component as quickly as possible. If the internal temperature exceeds acceptable limits, the MSA70 may overheat and automatically shut down or restart.
- Parts can be damaged by electrostatic discharge. Use proper anti-static protection.

Verifying component failure

Use the following methods to verify component failure:

- Check the power UID module status LED:
 - Blue** = Identified
 - Blue flashing** = Active remote management
 - Off** = No active remote management
- Check the host log for errors.

Removing the power UID module

1. Power down the enclosure:
 - a. Power down any attached servers. See the server documentation.
 - b. Press the Power On/Standby button on the enclosure.
 - c. Wait for the system power LED to go from green to amber.
 - d. Disconnect the power cords.
2. Extend or remove the enclosure from the rack in which it may be installed:
 - a. Loosen the front panel thumbscrews that secure the enclosure faceplate to the front of the rack.
 - b. Disconnect the cabling and extend or remove the enclosure from the rack.
3. Remove the access panel:
 - a. Lift the access panel latch (1).
 - b. Slide the access panel to the rear (2).

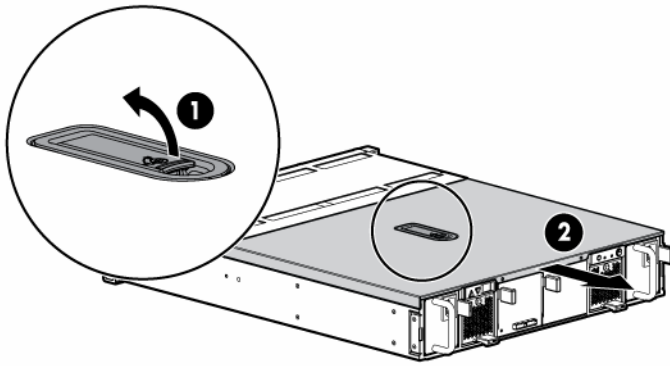

15484

4. Disconnect the cable from the midplane (1).
5. Remove the T-15 screw securing the module to the chassis (2) and lift the module out of the chassis (3).

CAUTION:

Be careful not to accidentally drop the screw into the chassis when removing it from the module.

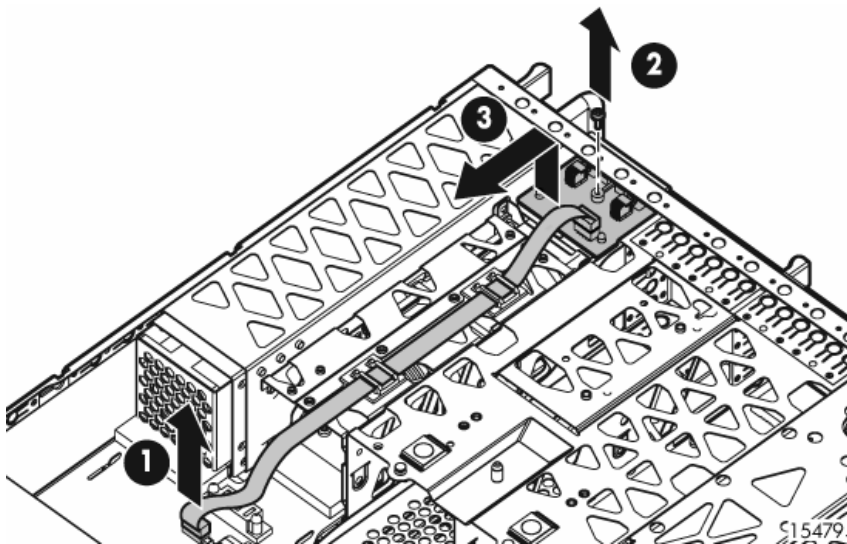

Installing the power UID module

To install the power UID module, reverse the removal procedure:

1. Insert the module into the chassis and secure it with a T-15 screw.
2. Connect the cable to the midplane.
3. Install the access panel.
4. Insert the enclosure into the rack and power up the enclosure.

Verifying component replacement

After replacing the power UID module, check the power UID module status LED.

7-segment display board

Before you begin

CAUTION:

- Before removing the failed component, make sure that you have the replacement part available. Removing a component impacts the airflow and cooling ability of the device.
- Do not remove more than one component or blank from the enclosure at a time. Doing so impacts the airflow and cooling ability of the device. To avoid possible overheating, insert the new or replacement component as quickly as possible. If the internal temperature exceeds acceptable limits, the MSA70 may overheat and automatically shut down or restart.
- Parts can be damaged by electrostatic discharge. Use proper anti-static protection.

Verifying component failure

Use the following methods to verify component failure:

- Check the 7-segment display board LED display for activity. If the LED display is not illuminated, the component may have failed.

NOTE:

No power to the 7-segment display board can also be an indication of the failure of the riser board, the power supply, or the midplane.

- Check the host log for errors.

Removing the 7-segment display board

1. Power down the enclosure:
 - a. Power down any attached servers. See the server documentation.
 - b. Press the Power On/Standby button on the enclosure.
 - c. Wait for the system power LED to go from green to amber.
 - d. Disconnect the power cords.
2. Extend or remove the enclosure from the rack in which it may be installed:
 - e. Loosen the front panel thumbscrews that secure the enclosure faceplate to the front of the rack.
 - f. Disconnect the cabling and extend or remove the enclosure from the rack.
3. Remove the access panel:
 - a. Lift the access panel latch (1).
 - b. Slide the access panel to the rear (2).

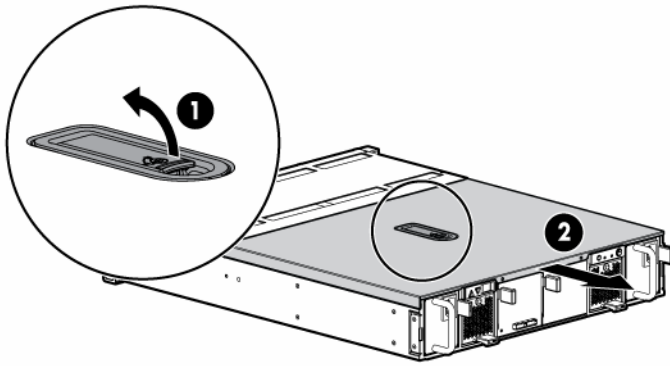

15484

4. Pull out the pin to release the board (1).
5. Put your finger inside the slot to slide the board out of the chassis (2).

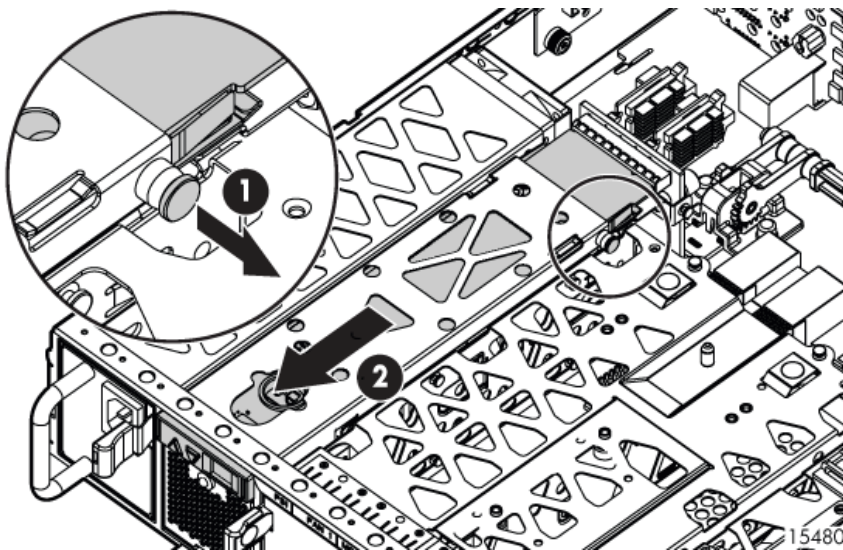

15480

Installing the 7-segment display board

To install the board, reverse the removal procedure:

1. Slide the board into the chassis and insert the pin to secure it.
2. Install the access panel.
3. Insert the enclosure into the rack and power up the enclosure.

Verifying component replacement

After replacing the 7-segment display board, check the 7-segment display board LED display to verify the board is operating normally.

Riser board

Before you begin

CAUTION:

- Before removing the failed component, make sure that you have the replacement part available. Removing a component impacts the airflow and cooling ability of the device.
- Do not remove more than one component or blank from the enclosure at a time. Doing so impacts the airflow and cooling ability of the device. To avoid possible overheating, insert the new or replacement component as quickly as possible. If the internal temperature exceeds acceptable limits, the MSA70 may overheat and automatically shut down or restart.
- Parts can be damaged by electrostatic discharge. Use proper anti-static protection.

Verifying component failure

Use the following methods to verify component failure:

- Check to see if there is power to the 7-segment display board. If the LED on the 7-segment display board is not illuminated, the riser board may have failed.

NOTE:

No power to the 7-segment display board can also be an indication of the failure of the 7-segment display board, the power supply, or the midplane.

- Check the host log for errors.

Removing the riser board

1. Power down the enclosure:
 - a. Power down any attached servers. See the server documentation.
 - b. Press the Power On/Standby button on the enclosure.
 - c. Wait for the system power LED to go from green to amber.
 - d. Disconnect the power cords.
2. Extend or remove the enclosure from the rack in which it may be installed:
 - a. Loosen the front panel thumbscrews that secure the enclosure faceplate to the front of the rack.
 - b. Disconnect the cabling and extend or remove the enclosure from the rack.
3. Remove the access panel:
 - a. Lift the access panel latch (1).
 - b. Slide the access panel to the rear (2).

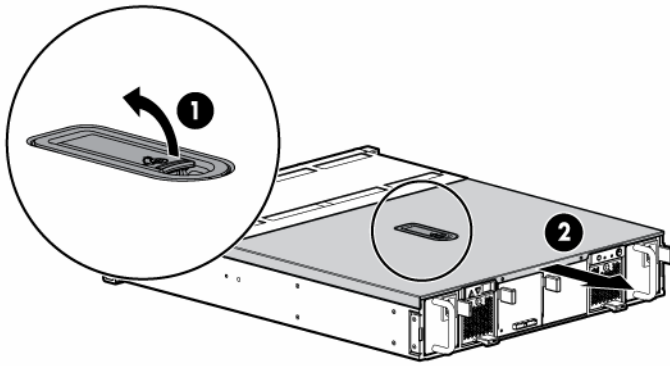

15484

4. Remove the 7-segment display board:
 - a. Pull out the pin to release the board (1).
 - b. Put your finger inside the slot to slide the board out of the chassis (2).

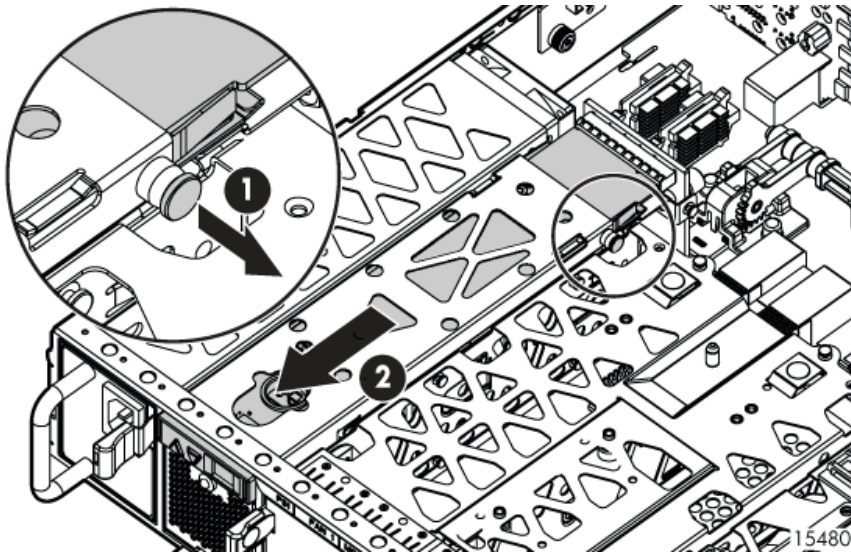

15480

5. Loosen the thumbscrew (1) and lift the riser board out of the chassis (2).

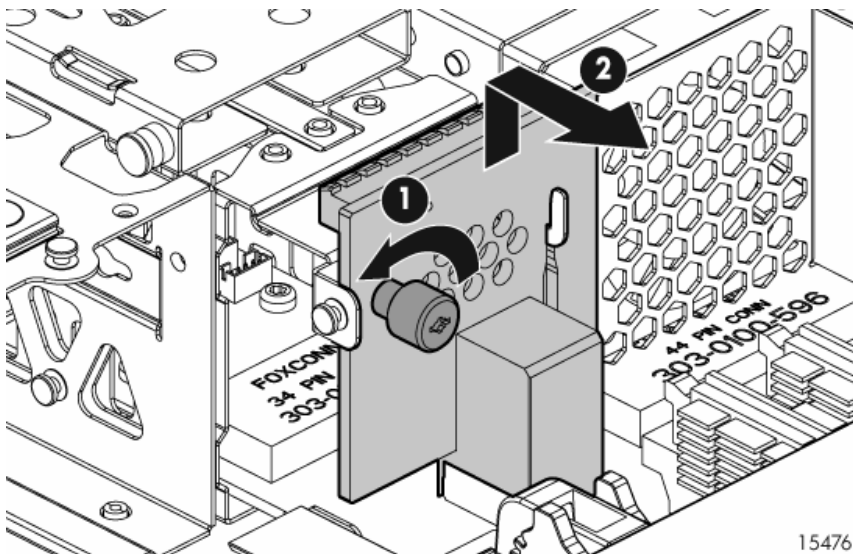

15476

Installing the riser board

To install the riser board, reverse the removal procedure:

1. Attach the board to the chassis, securing it with the thumbscrew.
2. Install the access panel.
3. Insert the enclosure into the rack and power up the enclosure.

Verifying component replacement

After replacing the riser board, be sure there is power to the 7-segment display board.

Midplane

Before you begin

CAUTION:

- Before removing the failed component, make sure that you have the replacement part available. Removing a component impacts the airflow and cooling ability of the device.
- Do not remove more than one component or blank from the enclosure at a time. Doing so impacts the airflow and cooling ability of the device. To avoid possible overheating, insert the new or replacement component as quickly as possible. If the internal temperature exceeds acceptable limits, the MSA70 may overheat and automatically shut down or restart.
- Parts can be damaged by electrostatic discharge. Use proper anti-static protection.

Verifying component failure

Use the following methods to verify component failure:

- Check the host log for errors.
- Check the following component status LEDs as identified in the following tables:
 - Hard drives—test with known good hard drives.
 - I/O module—test with known good I/O module.
 - Fan module—test with known good fan module.

Hard drive LED combinations		
Online/activity LED (green)	Fault/UID LED (amber/blue)	Interpretation
On, off, or flashing	Alternating amber and blue	The drive has failed, or a predictive failure alert has been received for this drive; it also has been selected by a management application.
On, off, or flashing	Steadily blue	The drive is operating normally, and it has been selected by a management application.
On	Amber, flashing regularly (1 Hz)	A predictive failure alert has been received for this drive. Replace the drive as soon as possible.
On	Off	The drive is online, but it is not currently active.

Hard drive LED combinations		
Online/activity LED (green)	Fault/UID LED (amber/blue)	Interpretation
Flashing regularly (1 Hz)	Amber, flashing regularly (1 Hz)	Do not remove the drive. Removing a drive may terminate the current operation and cause data loss. The drive is part of an array that is undergoing capacity expansion or a stripe size migration, but a predictive failure alert has been received for this drive. To minimize the risk of data loss, do not replace the drive until the expansion or migration is complete.
Flashing regularly (1 Hz)	Off	Do not remove the drive. Removing a drive may terminate the current operation and cause data loss. The drive is rebuilding, or it is part of an array that is undergoing capacity expansion or a stripe size migration.
Flashing irregularly	Amber, flashing regularly (1 Hz)	The drive is active, but a predictive failure alert has been received for this drive. Replace the drive as soon as possible.
Flashing irregularly	Off	The drive is active and it is operating normally.
Off	Steadily amber	A critical fault condition has been identified for this drive and the controller has placed it offline. Replace the drive as soon as possible.
Off	Amber, flashing regularly (1 Hz)	A predictive failure alert has been received for this drive. Replace the drive as soon as possible.
Off	Off	The drive is offline, a spare, or not configured as part of an array.

I/O module and fan LEDs	
Item	Description
I/O module LED	Green = System activity Amber = Fault condition Off = No system activity
Fan LED	Green = Normal operation Amber = Fault condition Off = Fan unseated from connector or failed

Removing the midplane

1. Power down the enclosure:
 - a. Power down any attached servers. See the server documentation.
 - b. Press the Power On/Standby button on the enclosure.
 - c. Wait for the system power LED to go from green to amber.
 - d. Disconnect the power cords.
2. Extend or remove the enclosure from the rack in which it may be installed:
 - a. Loosen the front panel thumbscrews that secure the enclosure faceplate to the front of the rack.
 - b. Disconnect the cabling and extend or remove the enclosure from the rack.
3. Remove the access panel:
 - a. Lift the access panel latch (1).
 - b. Slide the access panel to the rear (2).

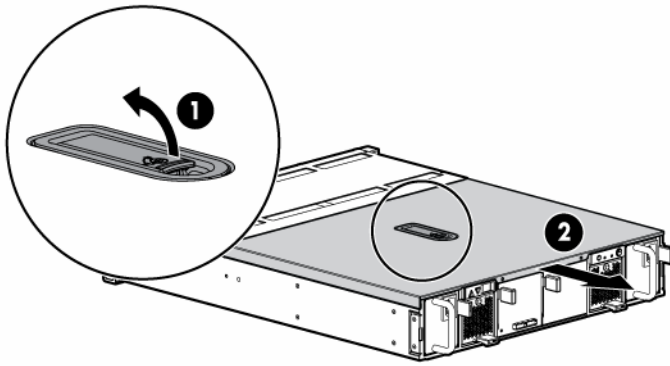

15484

4. Remove the power supplies:
 - a. Disconnect the power cord from the power supply.
 - b. Press the latch inward (1) and pull the power supply out of the chassis (2).
 - c. Repeat steps a and b for the redundant power supply.

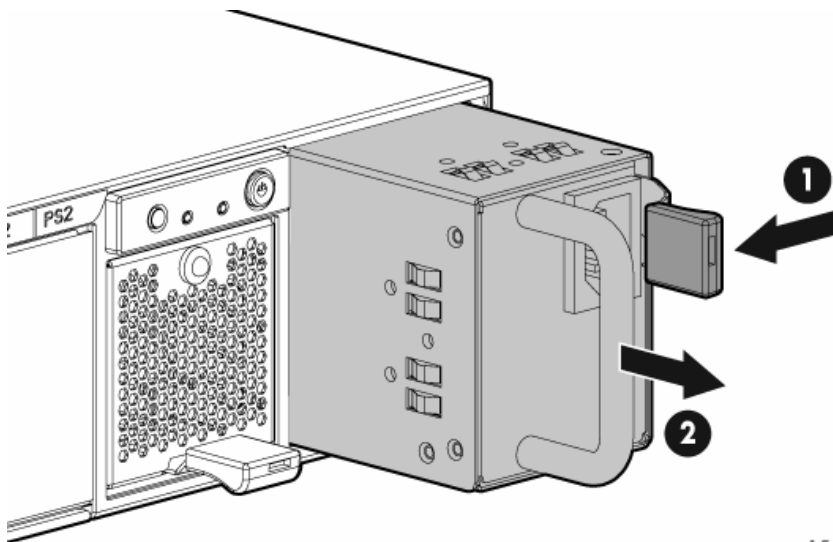

15473

5. Remove the fans:
 - a. Press up on the lever (1).
 - b. Slide the fan out of the chassis (2).
 - c. Repeat steps a and b for the redundant fan.

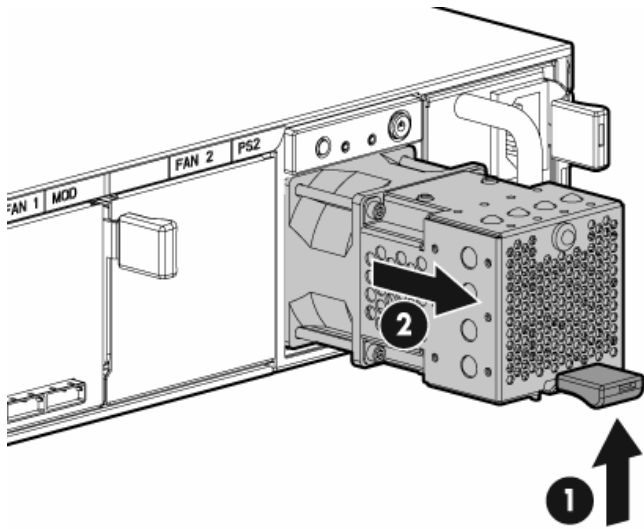

15474

6. Remove the I/O module:
 - a. Disconnect any SAS cables connected to the I/O module.
 - b. Squeeze the lever (1) and pull it down (2).
 - c. Slide the I/O module out of the chassis (3).

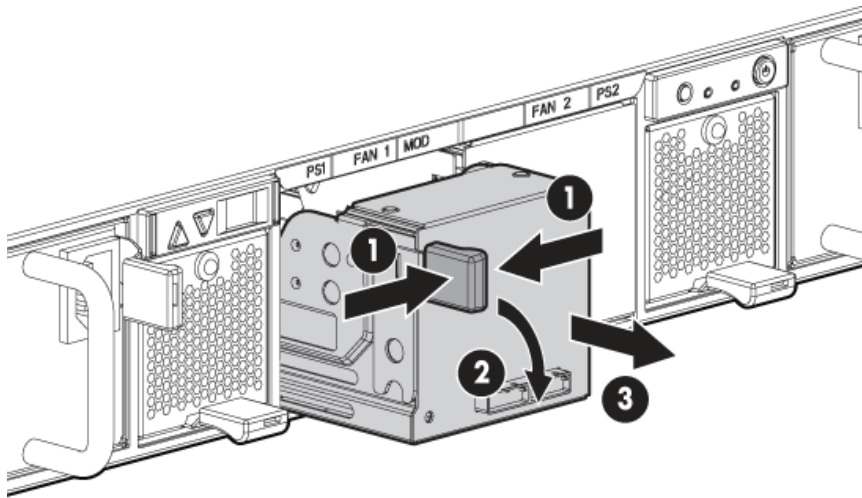

15475

7. Remove the I/O module blank:
 - a. Squeeze the lever (1) and pull it down (2).
 - b. Slide the I/O module blank out of the chassis (3).

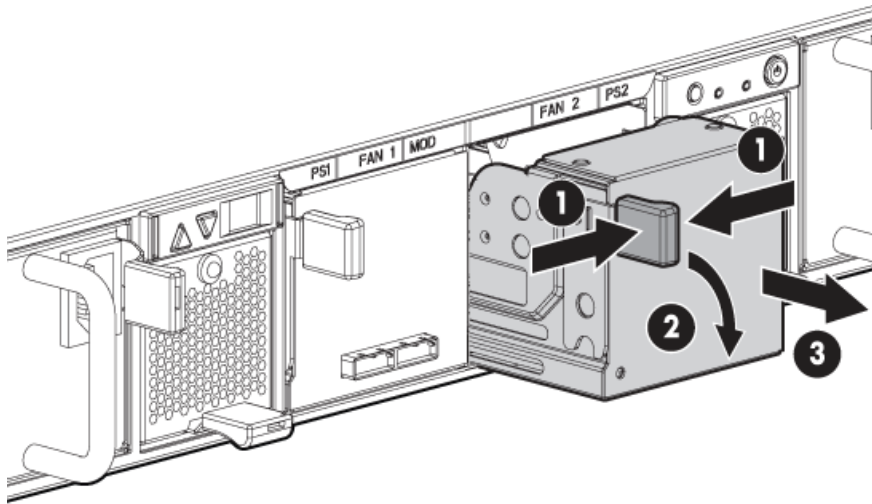

15483

8. Remove the 7-segment display board:
 - a. Pull out the pin to release the board (1).
 - b. Put your finger inside the slot to slide the board out of the chassis (2).

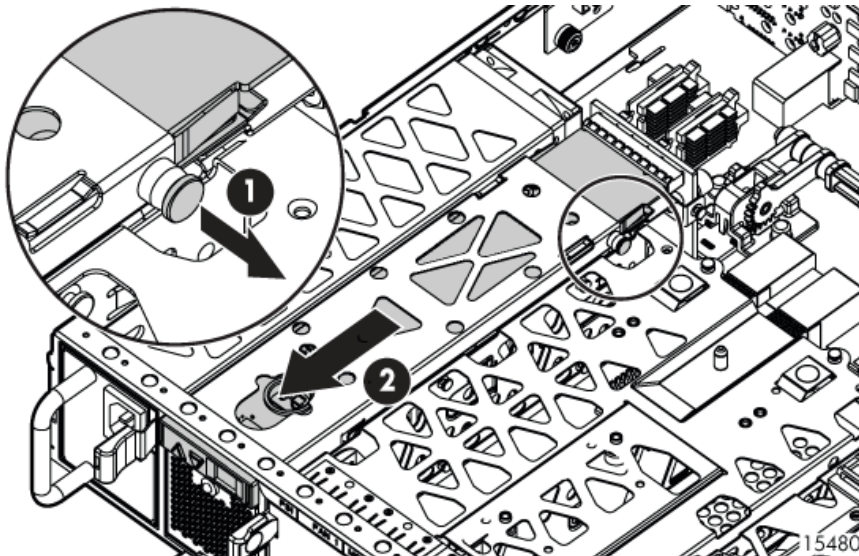

9. Remove the riser board by loosening the thumbscrew (1) and lifting the board out of the chassis (2).

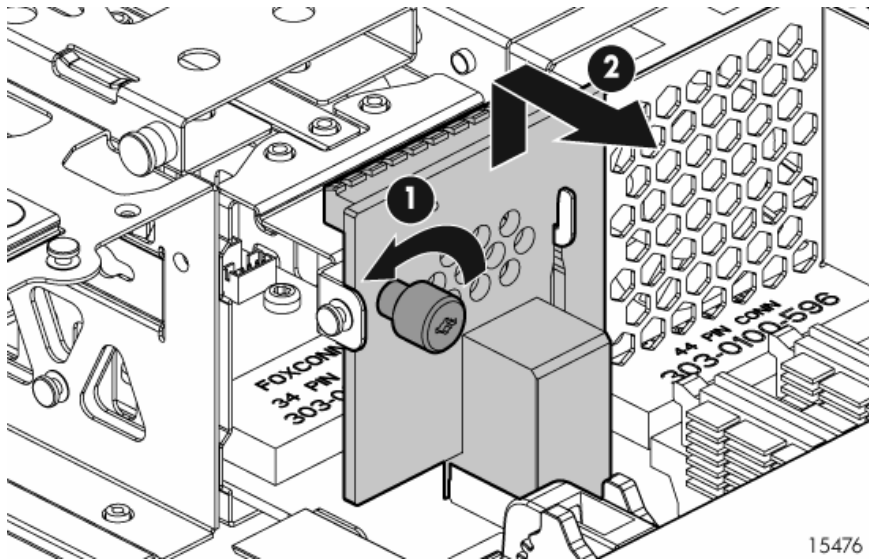

10. Disconnect the cables from the midplane.

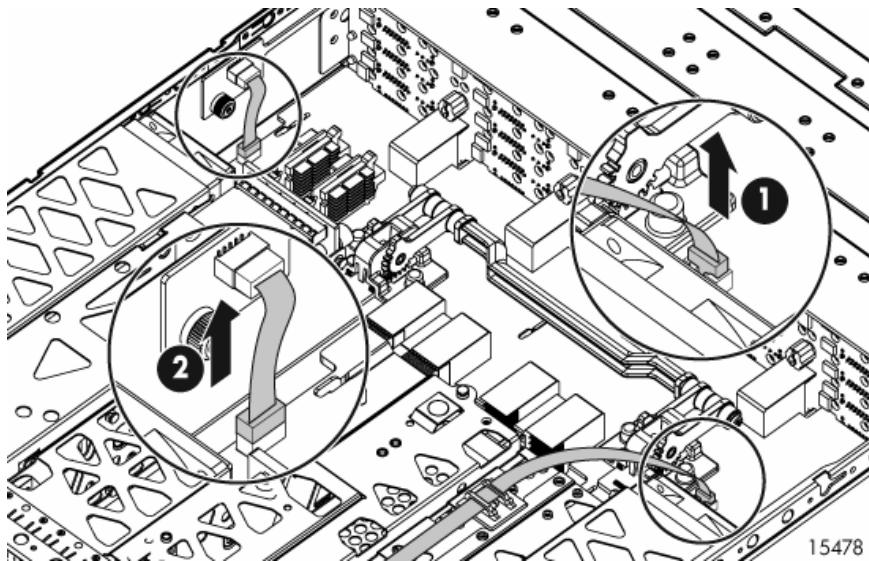

11. Lift the lever up to disengage the midplane from the backplane (1).

12. Tilt the midplane up and remove it from the chassis (2).

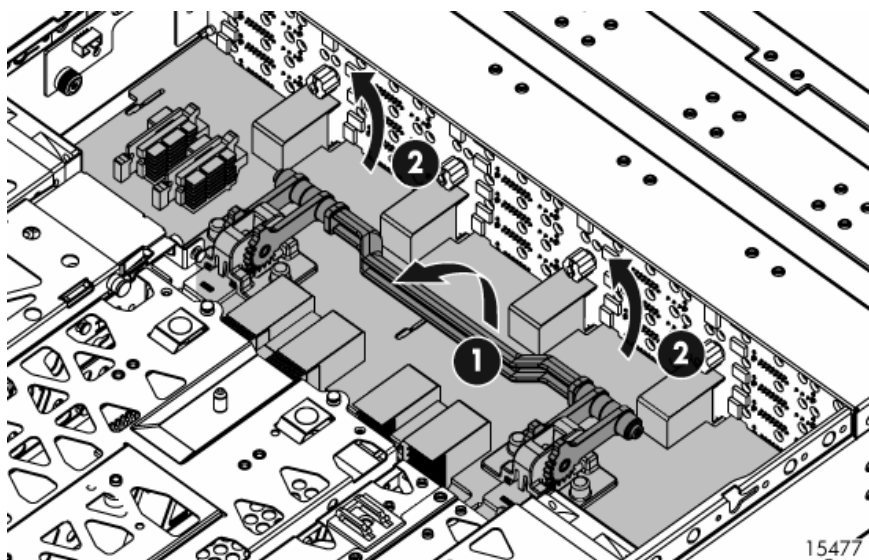

Installing the midplane

To install the midplane, reverse the removal procedure:

1. Insert the midplane into the chassis, making sure that it is engaged with the backplane. Then press the lever down to secure it in the chassis and connect the cables.
2. Install the riser board, 7-segment display board, I/O module and blank, fans, and power supplies.
3. Install the access panel.
4. Insert the enclosure into the rack and power up the enclosure.

Verifying component replacement

After replacing the midplane, check the following to verify the component is operating normally:

- Hard drive status LEDs
- I/O module status LED
- Fan module status LED

Backplane

Before you begin

CAUTION:

- Before removing the failed component, make sure that you have the replacement part available. Removing a component impacts the airflow and cooling ability of the device.
- Do not remove more than one component or blank from the enclosure at a time. Doing so impacts the airflow and cooling ability of the device. To avoid possible overheating, insert the new or replacement component as quickly as possible. If the internal temperature exceeds acceptable limits, the MSA70 may overheat and automatically shut down or restart.
- Parts can be damaged by electrostatic discharge. Use proper anti-static protection.

Verifying component failure

Use the following methods to verify component failure:

- Check the hard drive status LEDs as identified in the following table. Check with known good hard drives.
- Check the host log for errors.

Hard drive LED combinations		
Online/activity LED (green)	Fault/UID LED (amber/blue)	Interpretation
On, off, or flashing	Alternating amber and blue	The drive has failed, or a predictive failure alert has been received for this drive; it also has been selected by a management application.
On, off, or flashing	Steadily blue	The drive is operating normally, and it has been selected by a management application.
On	Amber, flashing regularly (1 Hz)	A predictive failure alert has been received for this drive. Replace the drive as soon as possible.
On	Off	The drive is online, but it is not currently active.
Flashing regularly (1 Hz)	Amber, flashing regularly (1 Hz)	Do not remove the drive. Removing a drive may terminate the current operation and cause data loss. The drive is part of an array that is undergoing capacity expansion or a stripe size migration, but a predictive failure alert has been received for this drive. To minimize the risk of data loss, do not replace the drive until the expansion or migration is complete.
Flashing regularly (1 Hz)	Off	Do not remove the drive. Removing a drive may terminate the current operation and cause data loss. The drive is rebuilding, or it is part of an array that is undergoing capacity expansion or a stripe size migration.
Flashing irregularly	Amber, flashing regularly (1 Hz)	The drive is active, but a predictive failure alert has been received for this drive. Replace the drive as soon as possible.
Flashing irregularly	Off	The drive is active and it is operating normally.
Off	Steadily amber	A critical fault condition has been identified for this drive and the controller has placed it offline. Replace the drive as soon as possible.
Off	Amber, flashing regularly (1 Hz)	A predictive failure alert has been received for this drive. Replace the drive as soon as possible.
Off	Off	The drive is offline, a spare, or not configured as part of an array.

Removing the backplane

1. Power down the enclosure:
 - a. Power down any attached servers. See the server documentation.
 - b. Press the Power On/Standby button on the enclosure.
 - c. Wait for the system power LED to go from green to amber.
 - d. Disconnect the power cords.
2. Extend or remove the enclosure from the rack in which it may be installed:
 - a. Loosen the front panel thumbscrews that secure the enclosure faceplate to the front of the rack.

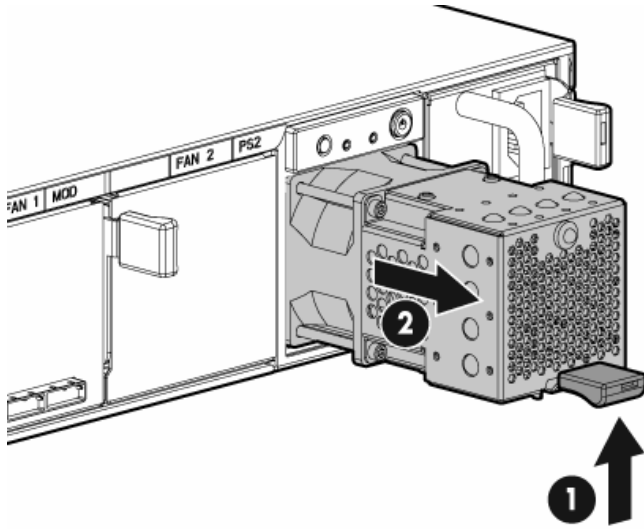

15474

- c. Remove the I/O module by disconnecting any SAS cables connected to the I/O module, squeezing the lever (1), pulling the lever down (2), and then sliding the module out of the chassis.

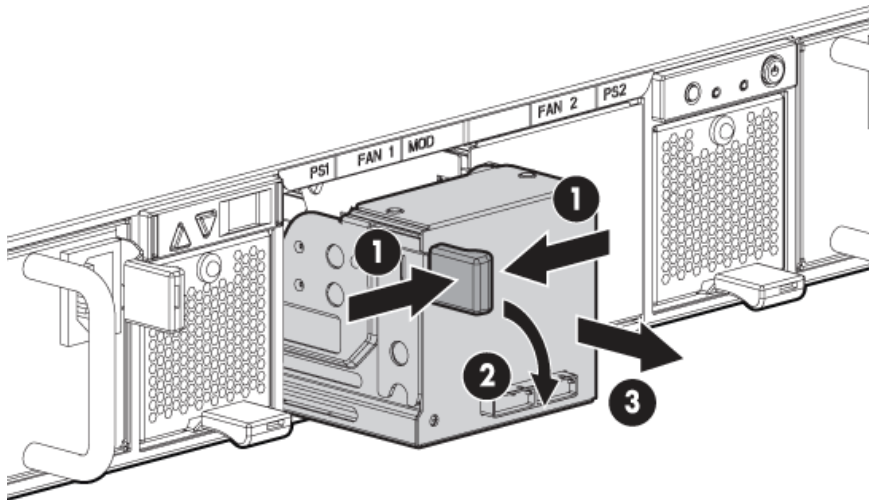

15475

- d. Remove the I/O module blank by squeezing the lever (1), pulling the lever down (2), and then sliding the blank out of the chassis.

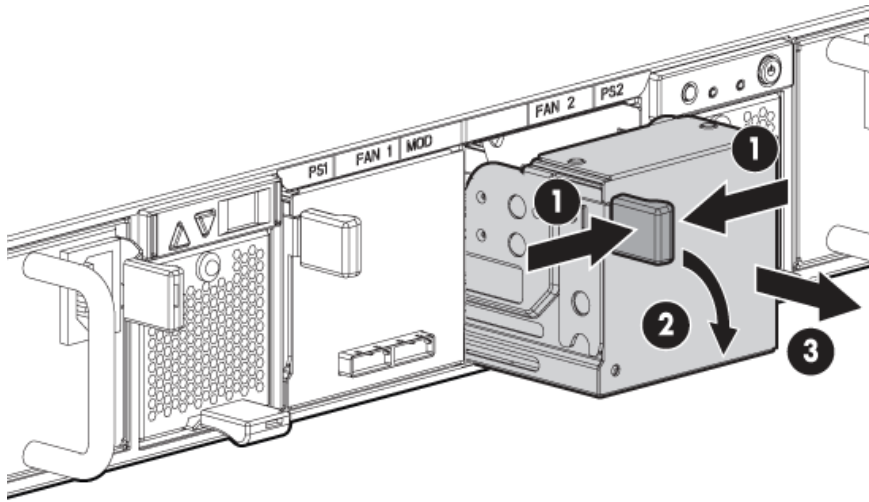

15483

- e. Remove the 7-segment display board by pulling the pin out to release the board (1), and then putting your finger inside the slot to slide the board out of the chassis (2).

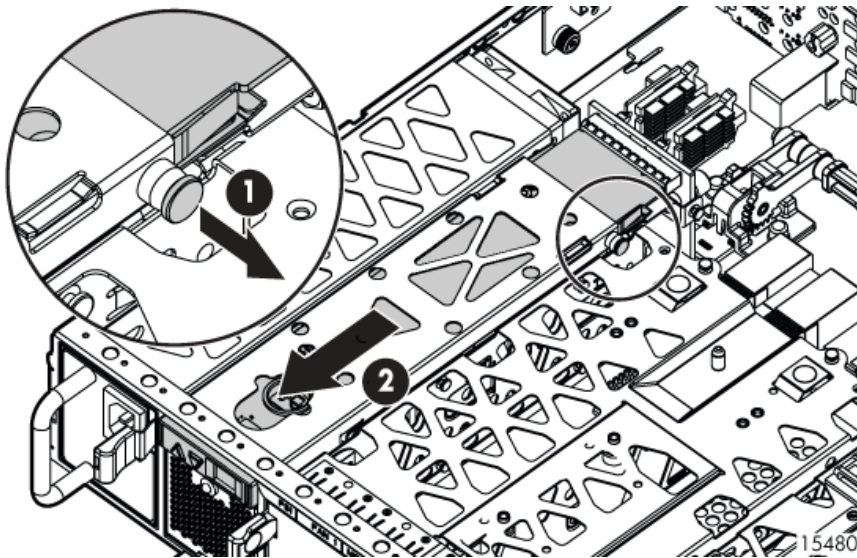

15480

- f. Remove the riser board by loosening the thumbscrew (1) and lifting the board out of the chassis (2).

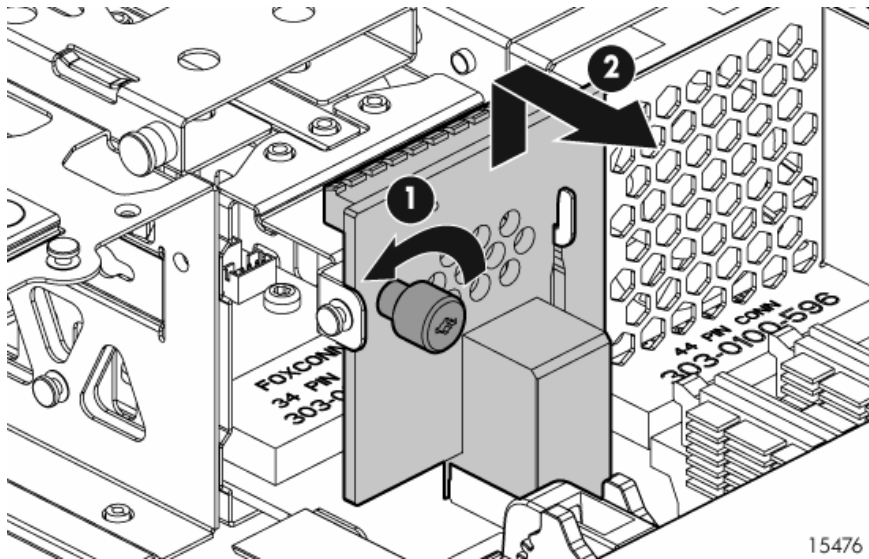

- g. Disconnect the cables from the midplane.

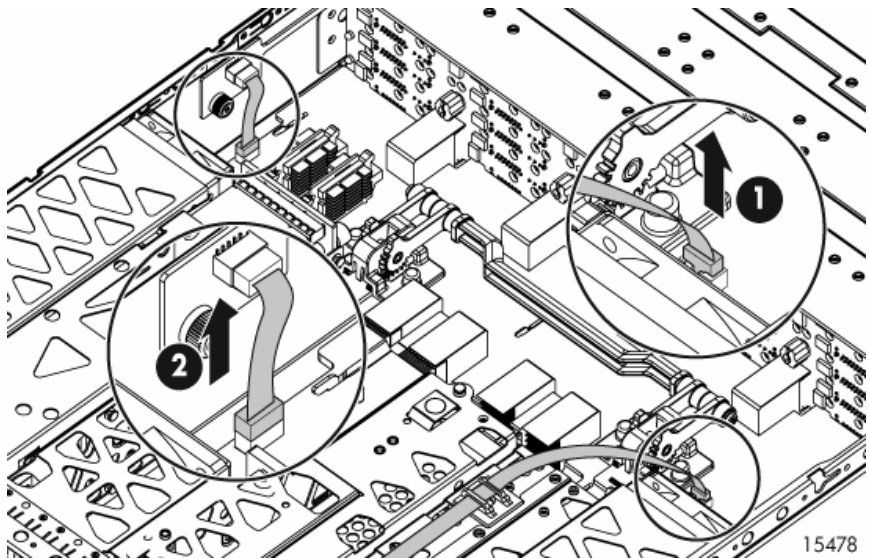

- h. Then lift the lever to disengage the midplane from the backplane (1), and then tilt the midplane up and remove it from the chassis (2).

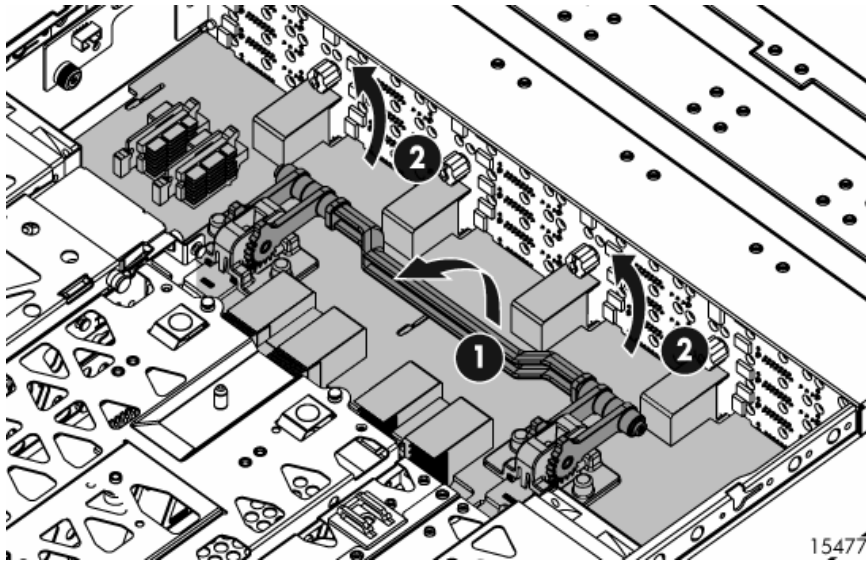

5. Remove the screws on the backplane (1).
6. Tilt the backplane up from the bottom and lift it out of the chassis (2).

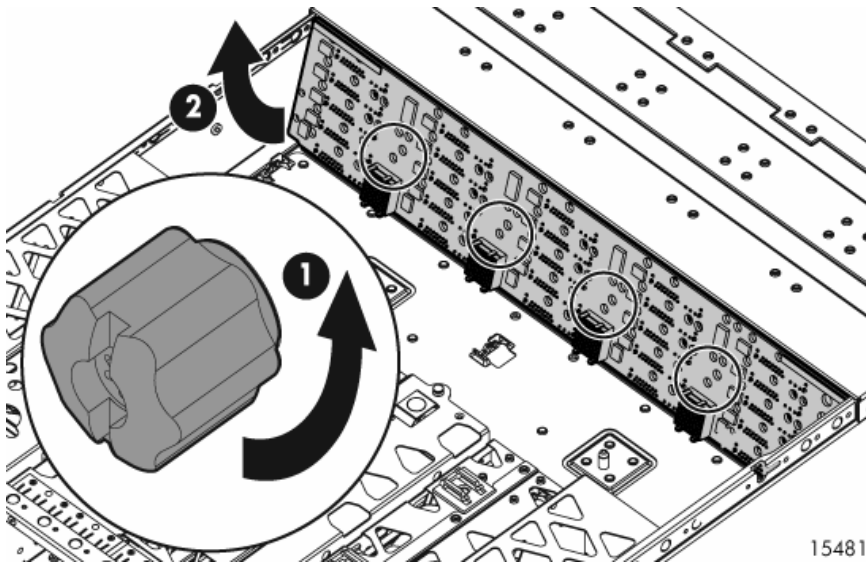

Installing the backplane

To install the backplane, reverse the removal procedure:

1. Insert the backplane into the chassis, securing it with the screw.
2. Install the midplane, riser board, 7-segment display board, I/O module and blank, fans, and power supplies.
3. Install the access panel.
4. Insert the enclosure into the rack and power up the enclosure.

Verifying component replacement

After replacing the backplane, check the hard drive status LEDs.

Updating firmware

After installing hardware and powering up the enclosure, be sure to verify that the host controller, the enclosure, and hard drives have the latest firmware. You can identify which firmware versions you have for the host controller, the MSA70, and the installed hard drives through HP SIM and ACU. ADU allows you to view the firmware versions for the host controller and hard drives, but not the MSA70.

NOTE:

The firmware for both the SAS and SATA hard drives is upgradeable.

For firmware and software updates, see the HP website:

<http://h18004.www1.hp.com/support/files/storage/us/index.html>. You can also update the firmware on the server, controller, enclosure, and hard drives using Smart Components. See the section “Smart Components for ROM Flash” in the MSA70 user guide.

You can receive proactive support alerts, such as Customer Advisories, as well as updates on drivers, software, firmware, and customer replaceable components, via e-mail through HP Subscriber's Choice. Sign up for Subscriber's Choice at the following HP website: <http://www.hp.com/go/myadvisory> and select the appropriate product.

Acronyms and abbreviations

ACU

Array Configuration Utility

ADG

Advanced Data Guarding (also known as RAID 6)

ADU

Array Diagnostics Utility

IML

Integrated Management Log

MSA

Modular Smart Array

MSA70

Modular Smart Array 70

RAID

redundant array of inexpensive (or independent) disks

SAS

serial attached SCSI

SATA

serial ATA

SCSI

small computer system interface

SIM

Systems Insight Manager

TMRA

recommended ambient operating temperature

UID

unit identification

WEBES

Web-Based Enterprise Service

Index

7

- 7-segment display board 41
 - installing 42
 - removing 41

A

- access panel 26
 - installing 27
 - removing 26
- ADU See Array Diagnostic Utility
- Array Diagnostic Utility 18

B

- backplane 51
 - installing 57
 - removing 52
- buttons 13

C

- cables, supported 12
- component failure, verifying
 - 7-segment display board 41
 - backplane 52
 - front UID module 34
 - hard drive 28
 - hot-plug fan 32
 - hot-plug power supply 31
 - I/O module 33
 - midplane 45
 - power on/off module 36
 - power UID module 39
 - riser board 43
- component identification 13, 14
- component replacement, verifying
 - 7-segment display board 42
 - backplane 57
 - front UID module 35
 - hard drive 30
 - hot-plug fan 33
 - hot-plug power supply 31
 - I/O module 34

- midplane 51
- power on/off module 38
- power UID module 40
- riser board 45
- components
 - front panel 13
 - rear panel 14
- connectors 13
- CSR See customer self repair
- customer self repair 19, 20

D

- diagnostic tools 18

E

- enclosure specifications 11
- environmental specifications 11

F

- fan
 - installing 32
 - removing 32
- front panel components 13
- front panel LEDs 14
- front UID module 34
 - installing 35
 - removing 35

H

- hard drive
 - bay numbers 16
 - LEDs 16
- hard drive blanks 27
 - installing 27
 - removing 27
- hard drives 28
 - installing 30
 - removing 29
- hot-plug fans 32
- hot-plug power supplies 30
- HP technical support 7

I

- I/O module 33
 - installing 34
 - removing 33
- illustrated parts catalog 9
- IML See Integrated Management Log
- installing
 - 7-segment display board 42
 - access panel 27
 - backplane 57
 - fan 32
 - front UID module 35
 - hard drive blanks 27
 - hard drives 30
 - I/O module 34
 - midplane 51
 - power on/off module 38
 - power supply 31
 - power UID module 40
 - riser board 45
- Integrated Management Log 18

L

- LEDs 13
 - front panel 14
 - hard drive combinations 17
 - hard drives 16
 - rear panel 15

M

- management tools 18
- midplane 45
 - installing 51
 - removing 46

P

- power on/off module 36
 - installing 38
 - removing 36
- power supply
 - installing 31
 - removing 31
- power UID module 39
 - installing 40
 - removing 39
- powering down the enclosure 25, 26
- powering up the enclosure 25
- precautions 21

- prerequisites 6
- product warranties 7

R

- rear panel buttons 15
- rear panel components 14
- rear panel LEDs 15
- removal and replacement procedures 25
 - overview 19
- removing
 - 7-segment display board 41
 - access panel 26
 - backplane 52
 - fan 32
 - front UID module 35
 - hard drive blanks 27
 - hard drives 29
 - I/O module 33
 - midplane 46
 - power on/off module 36
 - power supply 31
 - power UID module 39
 - riser board 43
- riser board 43
 - installing 45
 - removing 43

S

- specifications 11
 - enclosure 11
 - environmental 11
- subscription service 8
- supported cables 12
- system components 9

T

- technical support 7
- tools 18
 - diagnostic 18
 - management 18
 - recommended 21
 - utilities 18

U

- utilities 18

W

- warnings 21

warranties 7

warranty service, parts only 20